



## INSTALLATION AND OPERATION INSTRUCTIONS

**OWNER / INSTALLER:** For your safety this manual must be carefully and thoroughly read and understood before installing, operating or servicing this heater.

### RSTP SERIES INFRARED RADIANT TUBE HEATER Single Stage Pull Through System (Negative Pressure)

#### Models:

RSTP15C  
RSTP17C

**!INSTALLER:** This manual is the property of the owner. Please present this manual to the owner when you leave the job site.

**▲WARNING:** Improper installation, adjustment, alteration, service, or maintenance can cause property damage, injury or death. Read the installation, operation and maintenance instructions thoroughly before installing or servicing this equipment.

#### IF YOU SMELL GAS:

- ! **DO NOT** try to light any appliance.
- ! **DO NOT** touch any electrical switch; **DO NOT** use any telephone in your building.
- ! **IMMEDIATELY** call your gas supplier from a neighbor's telephone. Follow the gas supplier's instructions. If you cannot reach your gas supplier, call the fire department.

#### FOR YOUR SAFETY

**DO NOT** store or use gasoline or other flammable vapors and liquids in the vicinity of this or any other appliance.

**!IMPORTANT: SAVE THIS MANUAL FOR FUTURE REFERENCE.**

#### SPACE-RAY

Post Office Box 36485 (28236) • 305 Doggett Street (28203) • Charlotte, North Carolina  
Phone (704) 372-6391 • Fax (704) 332-5843 • www.spaceray.com • email: info@spaceray.com

## TABLE OF CONTENTS

<u>SECTION</u>	<u>DESCRIPTION</u>	<u>PAGE</u>
1.0)	Safety .....	2
2.0)	Installer Responsibility .....	2
3.0)	General Information.....	2
4.0)	Minimum Clearances to Combustibles.....	4
5.0)	Specifications.....	5
6.0)	Packing List.....	5
6.1)	Accessory Packages .....	5
7.0)	Dimensions .....	6
8.0)	Heater Assembly Overview .....	7
9.0)	Typical Suspension Methods .....	8
10.0)	Heater Assembly .....	10
11.0)	Gas Connections and Regulations.....	13
12.0)	Instructions for Pressure Test Gauge Connection.....	15
13.0)	Electrical Connections .....	16
14.0)	Venting.....	19
15.0)	Air for Combustion .....	23
15.1)	Direct Outside Air for Combustion.....	23
16.0)	Lighting and Shutdown Instructions.....	26
17.0)	Sequence of Operation.....	26
18.0)	Control Component Location.....	27
19.0)	Cleaning and Annual Maintenance .....	28
20.0)	Troubleshooting Guide.....	29
21.0)	Replacing Parts .....	32
21.1)	Removal of Spark Electrode and Flame Sensor.....	32
21.2)	Removing Main Burner and Gas Valve .....	33
21.3)	Air Switch Pressure Check.....	33
21.4)	Ignition System Checks.....	34
21.5)	Motor and Blower Wheel Check.....	35
22.0)	Installation Data .....	35
23.0)	Replacement Parts Guide.....	36

This heater complies with ANSI Z83.20 (current standard) and CSA 2.34. Copies of the National Fuel Gas Code (ANSI Z223.1-latest edition) are available from the CSA at 8501 East Pleasant Valley Road, Cleveland, Ohio 44131 or 55 Scarsdale Road, Don Mills, Ontario M3B 2R3. All NFPA codes are available from the National Fire Protection Association, Batterymarch Park, Quincy, Massachusetts 02269.

## 1.0) SAFETY

This heater is a self-contained infrared radiant tube heater. Safety information required during installation and operation of this heater is provided in this manual and the labels on the product. The installation, service and maintenance of this heater must be performed by a contractor qualified in the installation and service of gas fired heating equipment.

All personnel in contact with the heater must read and understand all safety information, instructions and labels before operation. The following symbols will be used in this manual to indicate important safety information.

### **WARNING**

**Warning** instructions must be followed to prevent or avoid hazards which may cause serious injury, property damage or death.

### **CAUTION**

**Caution** instructions must be followed to prevent incorrect operation or installation of the heater which may cause minor injury or property damage.

## 2.0) INSTALLER RESPONSIBILITY

The installer is responsible for the following:

- The heater and venting, as well as electrical and gas supplies must be installed in accordance with these installation instructions and any applicable codes and regulations.
- Every heater shall be located with respect to building construction and other equipment so as to permit access to the heater.
- Each installer must follow the clearances to combustible materials for the heaters.
- Install the heater so that the supports and hangers are correctly spaced in accordance with these instructions. The heater must be supported by materials having a working load limit of at least 115lbs. If a “trapeze” method is used, the chain, and turnbuckle must have a working load limit of at least 230lbs and the hooks must have a working load limit of at least 115lbs. All hooks must be crimped closed.
- Supply the owner with a copy of these Installation and Operation Instructions.
- Where unvented heaters are used, gravity or mechanical means shall be provided to supply and exhaust at least 4 CFM per 1,000 Btu/hr input of installed heaters.
- Never use the heater as a support for a ladder or other access equipment. Do not hang anything from the heater.
- Supply all installation materials necessary that are not included with the heater.
- Check the nameplate to make sure that the burner is correct for the gas type in the building and the installation altitude.

## 3.0) GENERAL INFORMATION

This heater is a self-contained infrared radiant tube heater for use in locations where flammable gases or vapors are not generally present (as defined by OSHA acceptable limits) and is intended for the heating of **nonresidential** spaces.

**For either indoor or outdoor installation. Not for use in residential dwellings.**

### **INSTALLATION REQUIREMENTS**

The installation must conform to local building codes or in the absence of local codes, with the National Fuel Gas Code ANSI Z223.1/NFPA54 or the Natural Gas and Propane Installation Code CSA B149.1. Heaters shall be installed by a licensed contractor or licensed installer. Clearances to combustibles as outlined in this manual should always be observed. In areas used for storage of combustible materials where they may be stacked below the heater, NFPA54 requires that the installer must post signs that will “specify the maximum permissible stacking height to maintain the required clearances from the heater to combustibles.”

Every heater shall be located with respect to building construction and other equipment so as to permit access to the heater. Each installer shall use quality installation practices when locating the heater and must give consideration to clearances to combustible materials, vehicles parked below, lights, overhead doors, storage areas with stacked materials, sprinkler heads, gas and electrical lines and any other possible obstructions or hazards. Consideration also must be given to service accessibility.

The heater, when installed in aircraft hangars and public garages, must be installed in accordance with ANSI/NFPA 409-latest edition (Standard for Aircraft Hangars), ANSI/NFPA 88a-latest edition (Standard for Parking Structures), and ANSI/NFPA 88b-latest edition (Standard for Repair Garages) with the following clearances:

- a. At least 10 feet above the upper surfaces of wings or engine enclosures of the highest aircraft that may be housed in the hangar and at least 8 feet above the floor in shops, offices, and other sections of hangars communicating with aircraft storage or service areas.
- b. At least 8 feet above the floor in public garages. **▲ WARNING:** Minimum clearances marked on the heater must be maintained from vehicles parked below the heater.

**(FOR CANADA ONLY)**

- a. Installation of this appliance is to be in accordance with latest edition of CSA B149.1 (Natural Gas and Propane Installation Code).
- b. For installation in public garages or aircraft hangars, the minimum clearances from the bottom of the infrared heater to the upper surface of the highest aircraft or vehicle shall be 50 percent greater than the certified minimum clearance, but the clearance shall not be less than 8 feet.

Although these heaters may be used in many applications other than space heating (e.g., process heating), Space-Ray will not recognize the warranty for any use other than space heating.

This heater is for Indoor or Outdoor Installation and can be used in either Vented or Unvented mode. The term Unvented actually means Indirect Vented. While the products of combustion are expelled into the building, national codes require ventilation in the building to dilute these products of combustion. This ventilation may be provided by gravity or mechanical means.

**This heater is not an explosion proof heater.** Where the possibility of exposure to volatile and low flash point materials exists, it could result in property damage or death. This heater must not be installed in a spray booth where the heater can operate during the spraying process. Consult your local fire marshal or insurance company.

**High Altitude:**

Appliances are supplied as standard for altitudes of 0 to 2,000 feet (0-610 m). High-altitude ratings are obtained by a change in the orifice size. When ordered for high altitude installations, burners are supplied by the factory ready for high altitude installation. Check the nameplate for altitude before proceeding with the installation. In Canada the adjustment for altitude is made in accordance with Standard CGA 2.17, Gas-Fired Appliances for Use at High Altitudes.

## 4.0) MINIMUM CLEARANCES TO COMBUSTIBLES

⚠ WARNING		
		<h3 style="margin: 0;">FIRE AND EXPLOSION HAZARD</h3> <p>Combustible material must be located outside the clearance dimensions listed.</p> <p>Failure to do so may result in death, serious injury or property damage.</p>

Minimum clearances to combustibles shall be measured from the outer surfaces as shown in the following diagram:

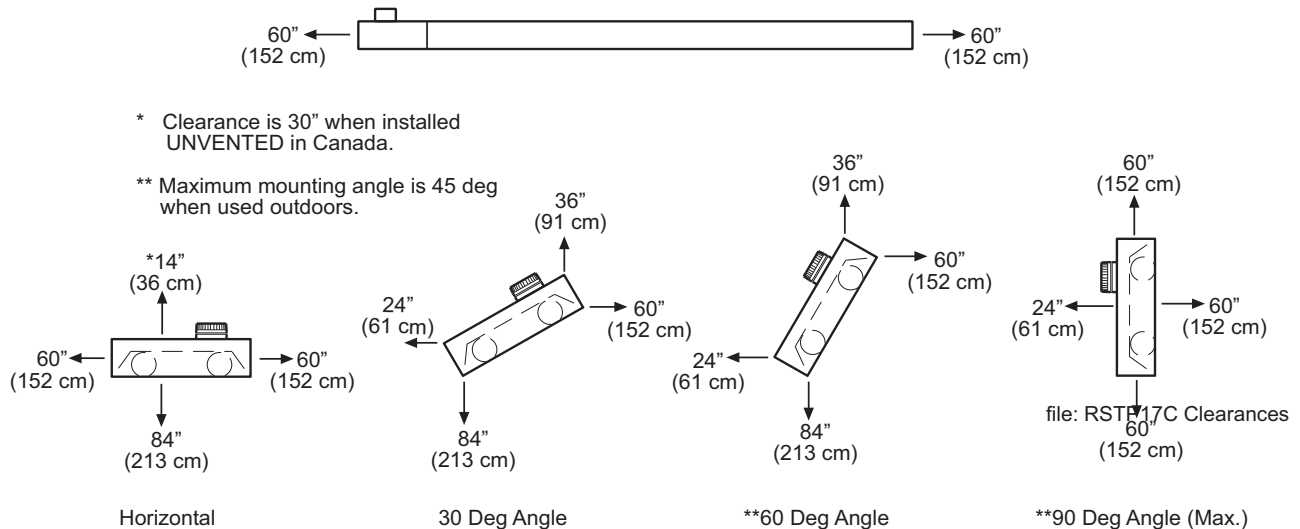

**▲ WARNING: Certain materials or objects, when stored under the heater, will be subjected to radiant heat and could be seriously damaged. Observe the Minimum Clearances to Combustibles listed in the manual and on the heater at all times.**

**NOTE:**

1. The clearances specified above must be maintained to combustibles and other materials that may be damaged by temperatures 90°F above ambient temperature. Clearances to combustibles are posted on the control box. In areas used for storage of combustible materials where they may be stacked below the heater, NFPA54 requires that the installer must post signs that will "specify the maximum permissible stacking height to maintain the required clearances from the heater to combustibles." Space-Ray recommends posting these signs adjacent to the heater thermostat or other suitable location that will provide enhanced visibility.
2. The stated clearance to combustibles represents a surface temperature of 90 °F (32 °C) above room temperature. Building materials with a low heat tolerance (such as plastics, vinyl siding, canvas, tri-ply, etc.) may be subject to degradation at lower temperatures. It is the installer's responsibility to assure that adjacent materials are protected from degradation.

## 5.0) SPECIFICATIONS

Model No.	Btu/hr Input	Orifice Size		Weight (lbs.)		Minimum * Mounting Height	
		Natural Gas	Propane Gas	Shipping	Unit	@ Horizontal	@ 45° Angle
RSTP15C-N5D	150,000	#1 (0.220)	n/a	256	216	14 ft.	12 ft.
RSTP17C-N5D	175,000	"D" (0.246)	n/a	256	216	16 ft.	14 ft.
RSTP17C-L5D	175,000	n/a	#26 (0.147)	256	216	16 ft.	14 ft.

\* MOUNT HEATERS AS HIGH AS POSSIBLE. Minimums are shown as a guideline for human comfort and uniform energy distribution for complete building heating applications. Consult your Space-Ray representative for the particulars of your installation requirements.

Type Gas	Gas Pipe Connection	Tube Diameter	Flue Connection	Fresh Air Connection	Electrical Supply	Current Rating
Natural or Propane	½" MPT (Male)	4"	6" Round	6" Round	120 Volt, 60Hz, 1 Phase	2.6 Amp

Fuse Rating:	Ignition System (direct spark):
Spark Module: 3 Amp 250V (for 24V Circuit)	30 second pre-purge period

## 6.0) PACKING LIST

### A. RSTP15C & RSTP17C Package

Part Description	QTY
Heater Assembly .....	1
Outlet Flue Collar (#42377000).....	1
Note, Lit. & Parts in Cabinet (#42799000) .....	1
Gas connector, 5/8" OD x 36" (#30302360) .....	1
Installation & Operation Instructions (#43206000) .....	1

### HEATER ASSEMBLY PACKAGE NUMBERS

NATURAL GAS		PROPANE GAS	
MODEL NO.	PART NO.	MODEL NO.	PART NO.
RSTP15C-N5D	#42363011	RSTP17C-L5D	#42363020
RSTP17C-N5D	#42363010		

## 6.1) ACCESSORY PACKAGES

### A. Indoor Unvented Kit, Part #42406000

Contains:

- Exhaust Hood, #42401000.....QTY-1
- #10-24 x 3/8 Screws, #02168010.....QTY-2
- Form, #42407000.....QTY-1

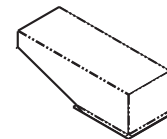

Exhaust Hood

### B. Outdoor Kit, Part #42411000

Contains:

- Exhaust Hood, #42401000.....QTY-1
- Inlet Air Hood, #42408000.....QTY-1
- Foam Strip, #42001040.....QTY-1
- #10-24 x 3/8 Screws, #02168010.....QTY-4
- Form, #42412000.....QTY-1

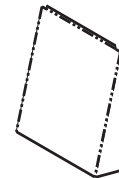

Inlet Air Hood

### C. "L" Bracket Kit for 90° mounting, Part #42929000

Contains:

- "L" Bracket, #42400000.....QTY-4



"L" Bracket

# 7.0) DIMENSIONS

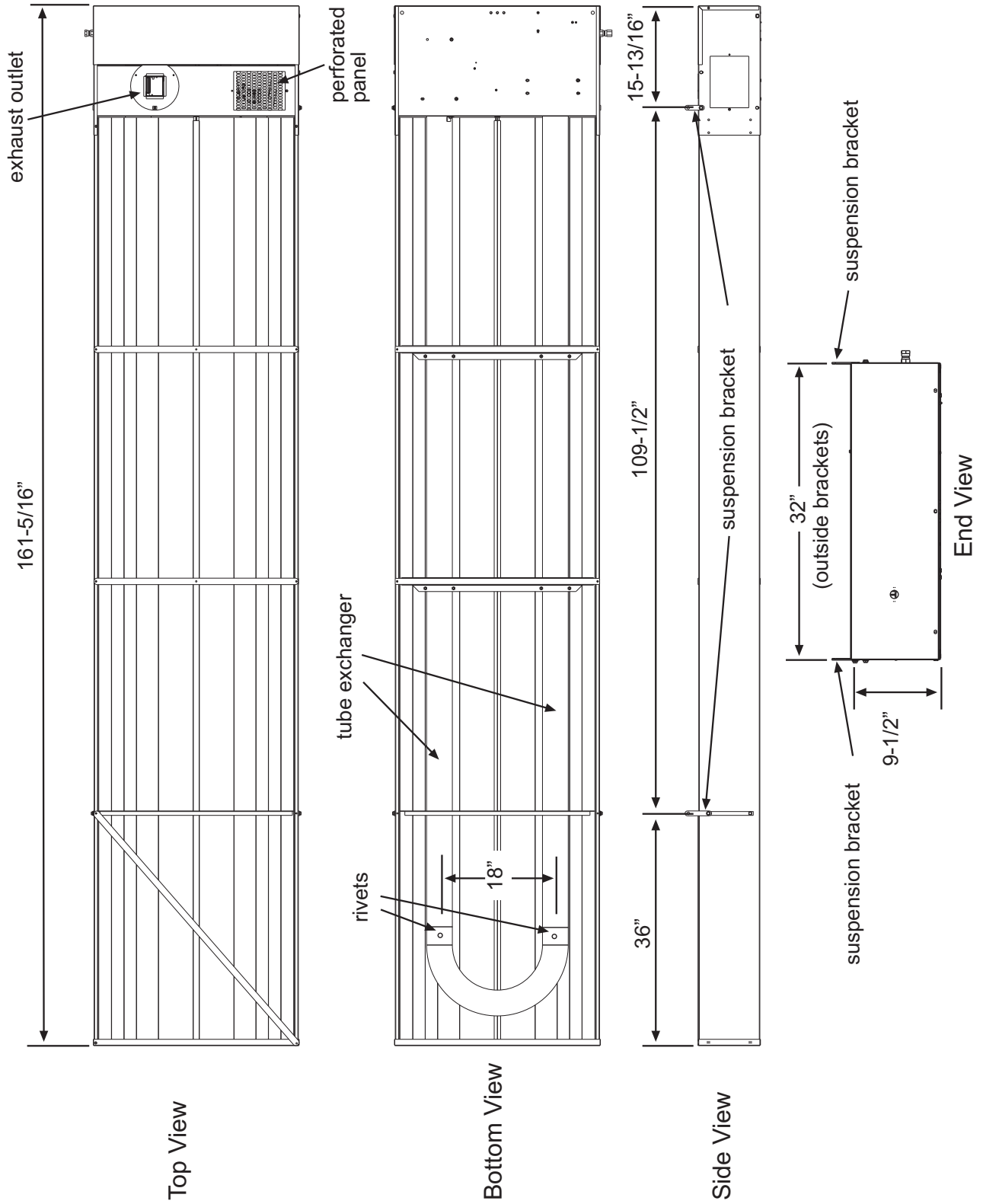

## 8.0) HEATER ASSEMBLY OVERVIEW

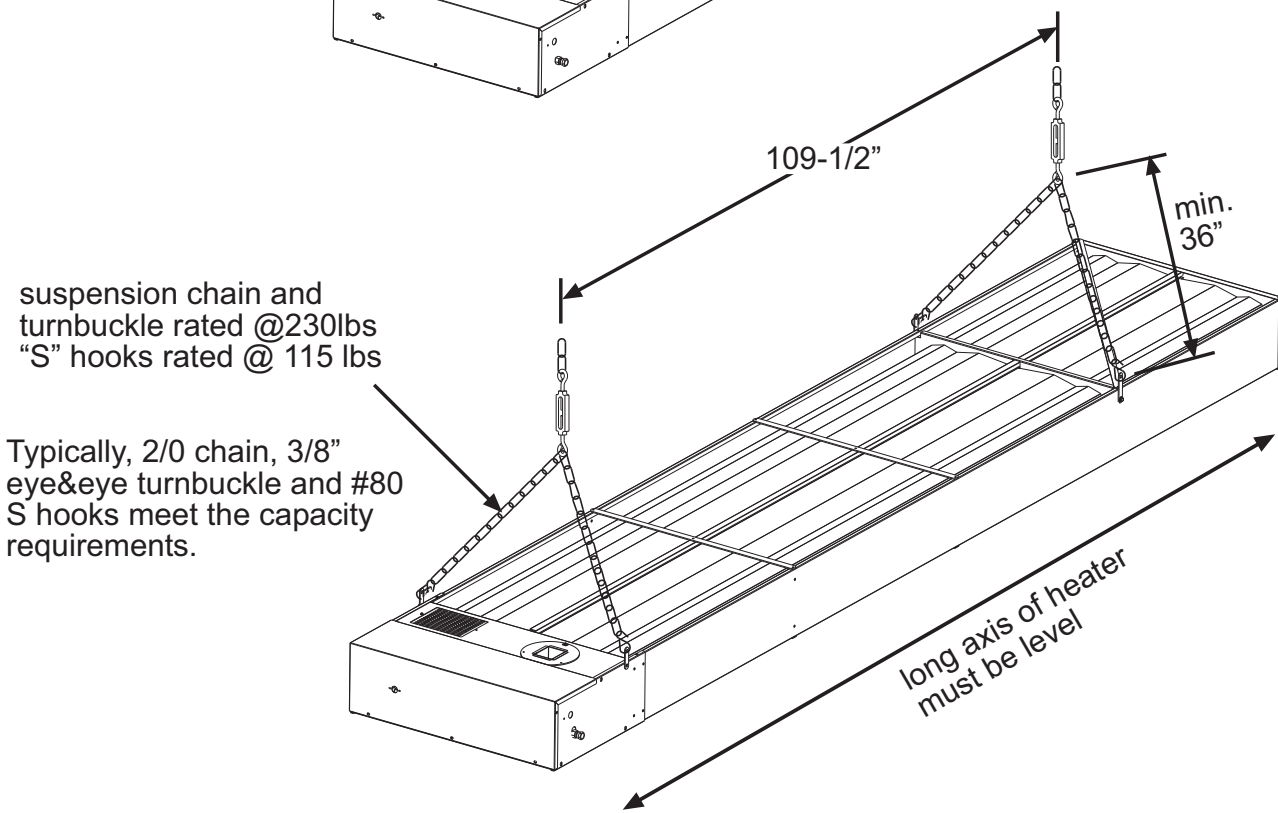
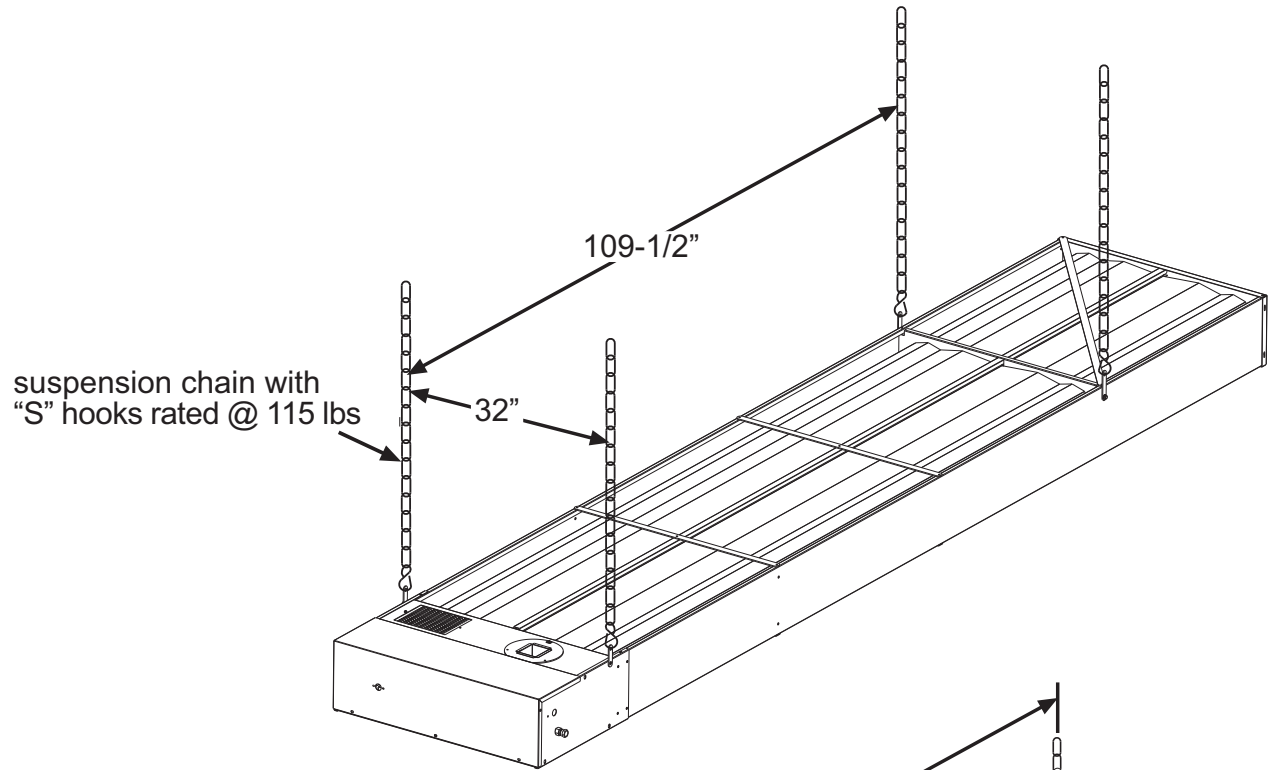



## 9.0) TYPICAL SUSPENSION METHODS

<b>⚠ WARNING</b>	
	<b>SUSPENSION HAZARD</b> All materials used to suspend the heater must have a minimum working load of 115 lbs. All "S" Hooks must be crimped closed.  If a "Trapeze" method of hanging is used, the chain and turnbuckle used to suspend the heater must have a minimum working load of 230 lbs. "S" hooks must have a minimum working load of 120 lbs.  Never use the heater to support a ladder or other access equipment.  Failure to do so may result in death, serious injury or property damage.

Various means of suspending the heater can be used. The following should be observed:

1. Use only noncombustible materials for suspending hangers and brackets.
2. Heaters must not be supported by gas or electric supply lines and must be suspended from a permanent structure with adequate load capacity.
3. Heaters subject to vibration must be provided with vibration isolating hangers.
4. A minimum No. 2 chain with a working load limit of 115 lbs. is required when using four (4) separate chains. If a "trapeze" method of hanging is desired, you must use a chain with a load limit of at least 230 lbs, a turnbuckle (if necessary) with a load limit of at least 230 lbs, and "S" hooks with a load limit of at least 115 lbs. Typically, 2/0 chain and 3/8" eye & eye turnbuckle have a minimum working load of 230 lbs; #80 "S" hooks have a minimum working load of 115 lbs.
5. Turnbuckles can be used with chains to allow leveling of the heater. All "S" hooks and eye bolts must be manually crimped closed by the installer.
6. When using rigid means for heater suspension (rod, flat bar, etc.) provide sufficient lengths or swing joints to compensate for expansion. See Figures b and c.
7. The heater can be mounted horizontally or at angles of 30°, 60°, or 90° indoors. The maximum mounting angle is 45° when installed outdoors. **The long axis of the heater should be level whether it is mounted horizontally or angled.**
8. If the heater is to be mounted horizontally or at an angle up to 60°, use the hanging brackets installed on the heater. See Figure 1 on Page 9.
9. If the heater is to be mounted at a 90° angle, remove the existing hanging brackets from each end of the heater and replace with "L" shaped brackets. See Figure 2 on Page 9. (**Note:** "L" shaped brackets are supplied as an accessory item. Order Kit No. 42929000.)
10. **IMPORTANT:** When the heater is angle mounted, the exhaust side should be up.

If a "trapeze" method is used for tube support/hanger brackets (shown below), the minimum chain length for the two connecting chains is 36" to minimize any vibration that might be generated by the draft inducer assembly. If these chains must be less than 36", then do not use the trapeze method and, instead, use individual chains on each tube support/hanger bracket.

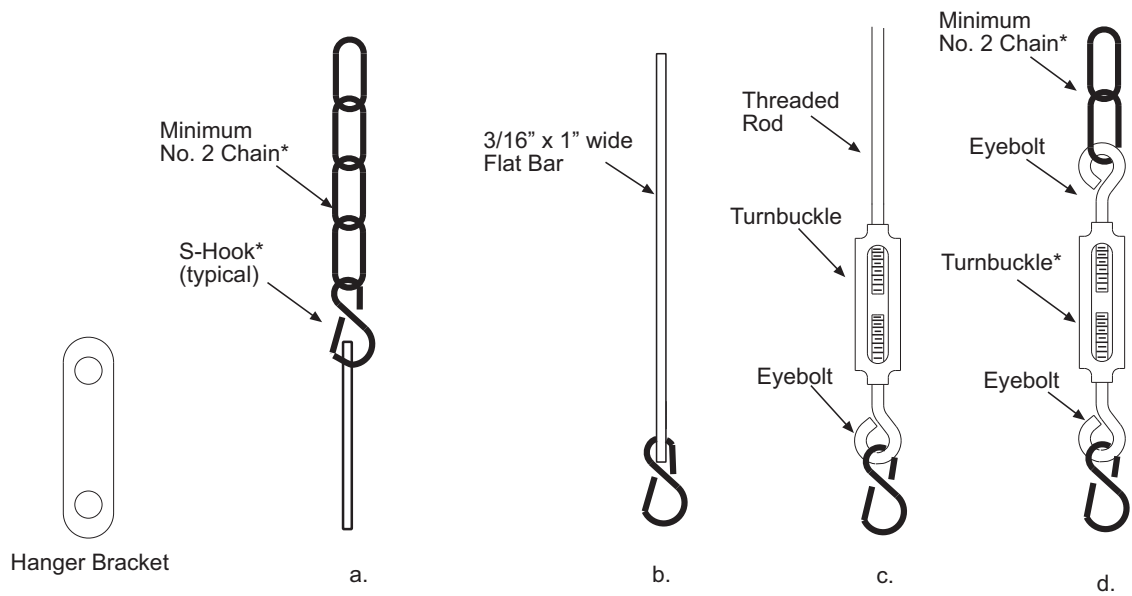

\* Minimum 2/0 chain, 3/8" eye & eye turnbuckle and #80 "S" hook should be used if a "trapeze" suspension method is desired.

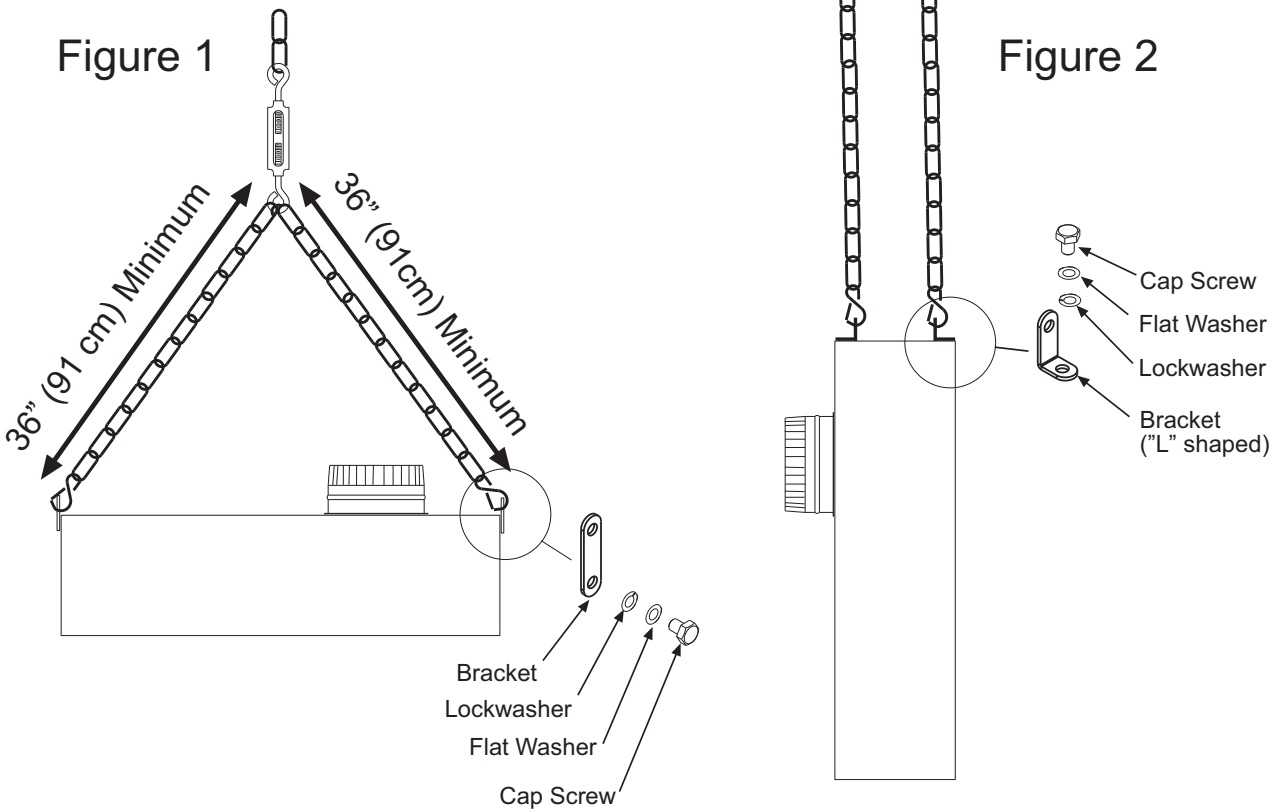

## 10.0) HEATER ASSEMBLY

<b>! CAUTION</b>	
	<b>CUT HAZARD</b> Sheet metal parts, particularly reflectors and vent have sharp edges. Always use gloves when handling.  Failure to do so may result in death, serious injury or property damage.

The heater is completely factory assembled. The gas manifold tubing requires field assembly; the recommended procedure is as follows:

1. Add the manifold tube and fittings. The required components are packaged inside the control box.
  - a. Remove the access panel. Apply pipe joint compound to the 5/8" tube x 1/2" Male NPT compression union and screw it into the valve. The pipe joint compound should be resistant to the action of liquefied petroleum gases.
  - b. Assemble the 5/8" tube x 1/2" Female NPT compression union to the opposite end of the manifold tube, then slide the manifold tube through the hole on control box.
  - c. Connect the manifold tube to the valve at the compression fitting. When connecting, use a wrench to hold the compression union on the valve.
  - d. Leak check the gas line up to the gas valve using soap solution method at a pressure of 14" w.c. Replace the access panel.

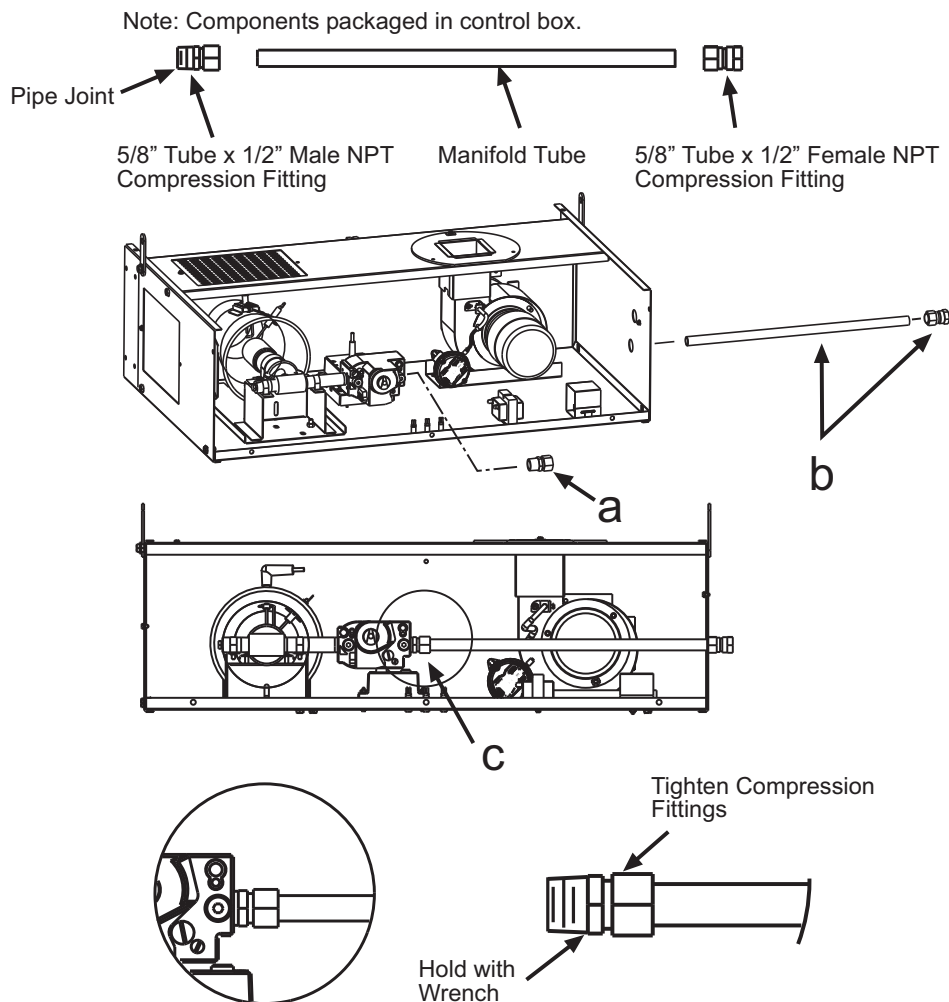

2. Install the suspension chains (according to Section 7.0) using proper suspension method (see Section 9.0).

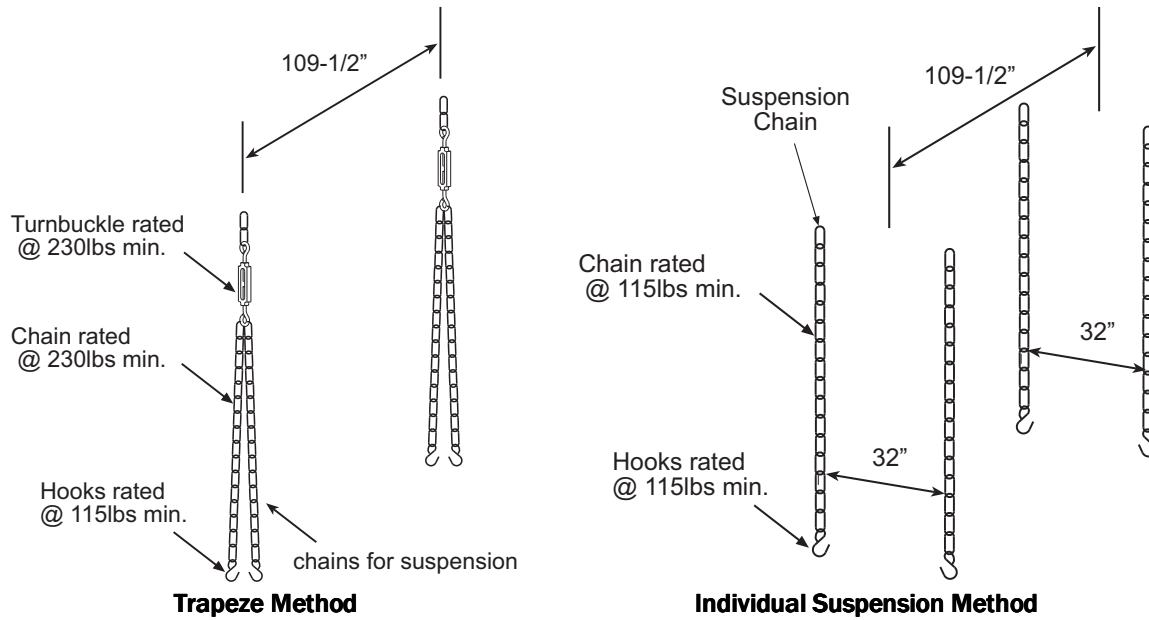

3. Lift the heater and suspend it into place. When lifting, caution should be used to avoid damaging the assembly. Make sure that the long axis of heater is level.

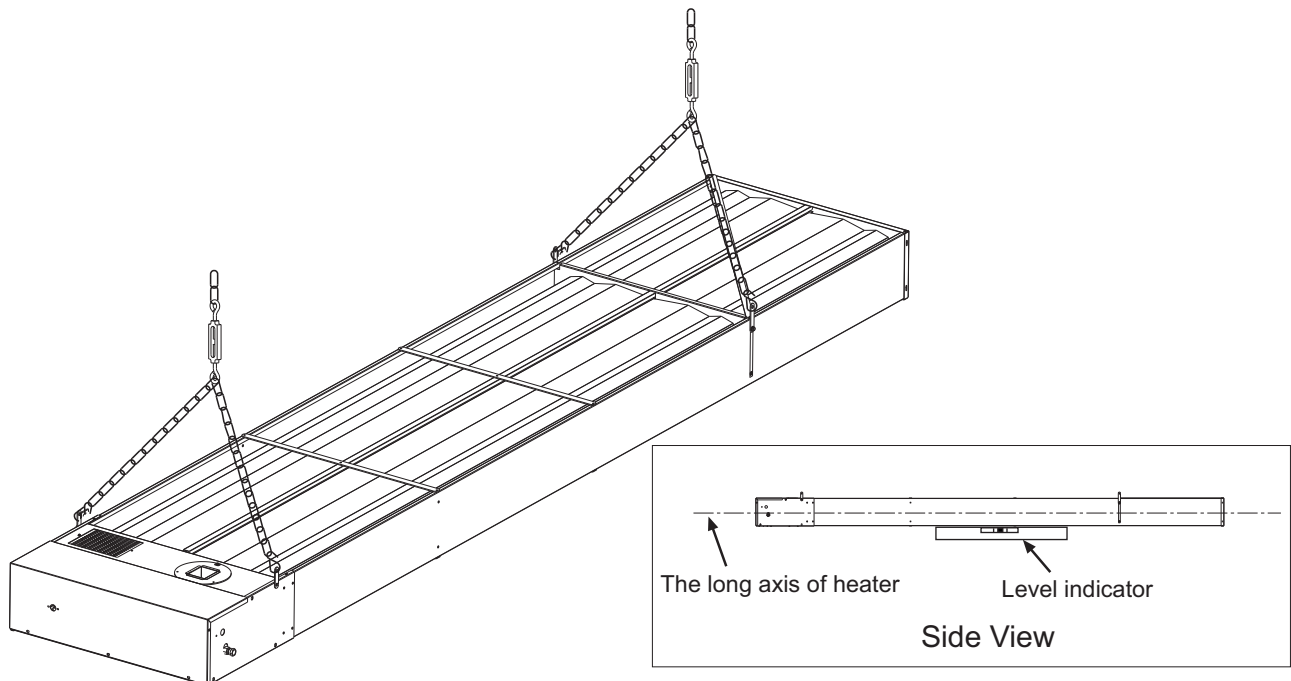

4. If the heater is to be used **Indoors and Vented** to the outside, install the flue collar supplied with the heater by placing the collar directly over the gasket. Secure the collar flange with clamps. See Figure 4 on next page.
5. Attach a 6" diameter flue pipe to the flue collar. Place an approved vent cap to the outside end of the flue pipe. See Section 14.0) for flue vent requirements.
6. If the heater is to be used **Indoors and Unvented**, order the Indoor Unvented Kit (Part #42406000). Remove the clamps and install the Exhaust Hood directly over the gasket. See Figure 5 on next page.
7. If the heater is to be used **Outdoors**, order the Outdoor Kit (Part #42411000). Install the Exhaust Hood as instructed above in #4. Remove the solid cover panel from the side and install the Inlet Air Hood. Remove the perforated cover panel from the top and replace it with the solid cover panel. See Figure 5 on next page. After completing the assembly, silicone sealant should be utilized to seal the access panel openings. If the installation site is subject to excessive wind conditions, it might be necessary to utilize pop rivets to secure the reflectors to the heater body.

**NOTE: EXHAUST HOODS AND INLET AIR HOODS ARE SUPPLIED AS ACCESSORY ITEMS. REFER TO THE PART NUMBERS BELOW TO ORDER THE KIT YOUR APPLICATION MAY REQUIRE.**

PART NO.	DESCRIPTION
42406000	Indoor Unvented Kit (includes Exhaust Hood)
42411000	Outdoor Kit (includes Exhaust Hood and Inlet Air Hood)

Figure 4 Indoor Installation Vented

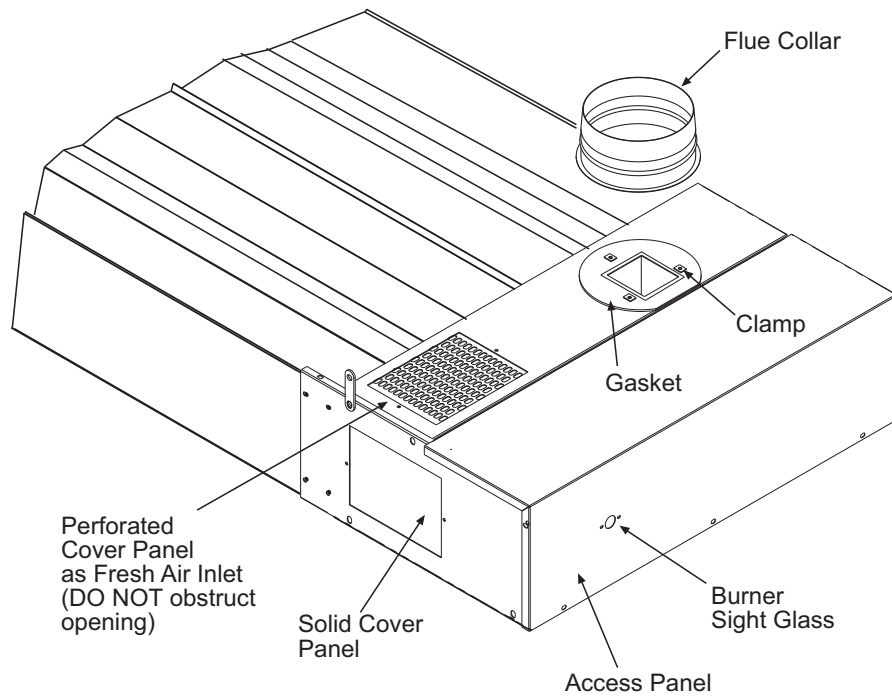
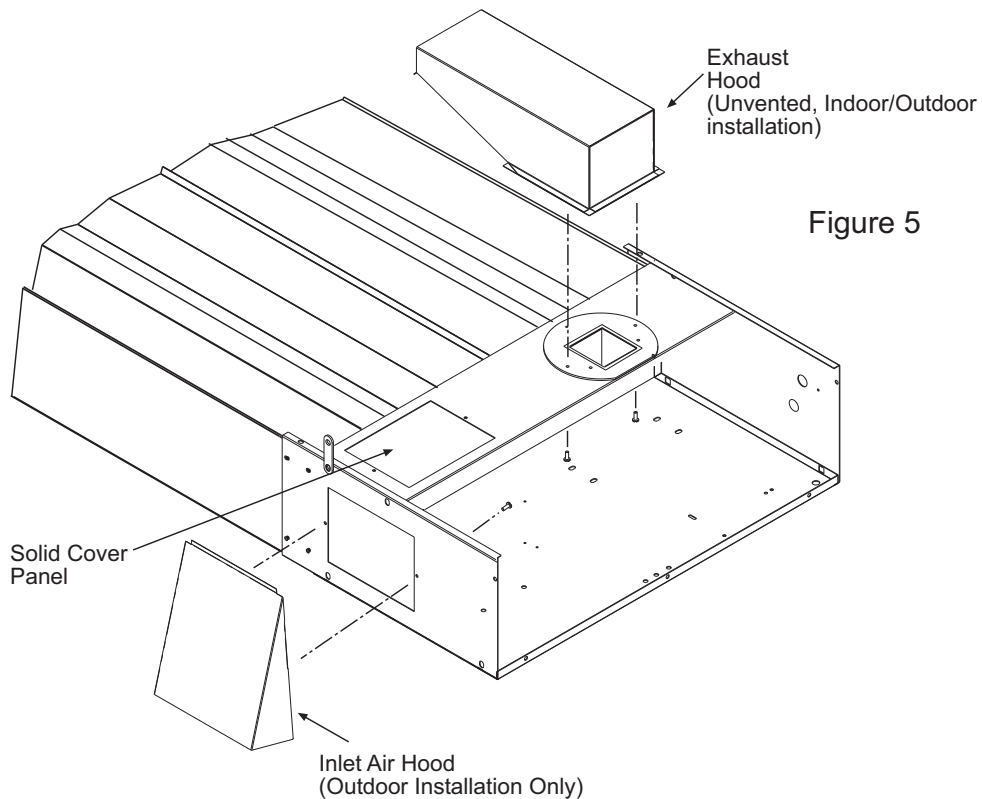

Figure 5



**Note: When the heater is angle mounted, the exhauster side should be up.**

## 11.0) GAS CONNECTIONS AND REGULATIONS

### ⚠ WARNING

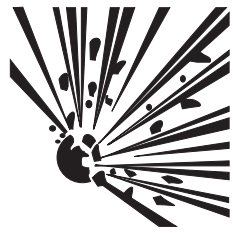

### FIRE AND EXPLOSION HAZARD

Tighten flexible gas hose and components securely.

Flexible metal gas hoses must be installed without any twists or kinks in them. The hose will move during operation of the heater and it can crack if it is twisted.

Failure to do so may result in death, serious injury or property damage.

### IMPORTANT BEFORE CONNECTING THE GAS TO THE HEATER

1. Connect to the supply tank or manifold in accordance with the latest edition of National Fuel Gas Code (ANSI Z223.1), and local building codes. Authorities having jurisdiction should be consulted before the installation is made. (In Canada, refer to the latest edition of CSA B149.1, Natural Gas and Propane Installation Code.)
2. Check that the gas fuel on the burner rating plate matches the fuel for the application.
3. Check that the gas supply piping has the capacity for the total gas consumption of the heaters and any other equipment connected to the line.
4. Check that the calculated supply pressure with all gas appliances and heaters operating will not drop below the minimum supply pressure required for these heaters. Check inlet supply pressures on Section 12.0).
5. All gas supply lines must be located in accordance with the required clearances to combustibles from the heater as listed on the clearances label of the heater and Section 4.0) of this manual.
6. Pipe joint compounds must be resistant to the action of liquefied petroleum gases.
7. Where local codes do not prohibit, a CSA or U.L. approved flexible connector supplied with this heater is required for connections between the rigid piping and the heater. A union should be installed before the control box inlet. An approved shut off valve should be installed within 6 feet of the union.
8. The gas pipe, flexible hose and connections must be self supporting. The gas pipe work must not bear any of the weight of the heater or any other suspended assembly.
9. This appliance is equipped with a step-opening, combination gas valve. **The maximum supply pressure to the appliance is 14" W.C. or 1/2 P.S.I.** If the line pressure is more than the maximum supply pressure, then a second stage regulator which corresponds to the supply pressure must be used.
10. After all gas connections have been made, make sure the heater and all gas outlets are turned off before the main gas supply is turned on slowly. Turn the gas supply on and check for leaks. To check for leaks, check by one of the methods listed in Appendix D of the National Fuel Gas Code.
11. All field installed gas connections **MUST** be checked for leakage along the gas line up to the gas valve.
12. If a 2nd stage regulator is used, the ball valve down stream in the supply line must be closed when purging the gas lines to prevent gas seeping through it. If initial gas pressure is higher than 14" w.c. the redundant combination gas valve is designed to lock out. Pressure build-up in the supply lines prior to the heater must be released before proper heater operation.

### ⚠ WARNING

**DO not use an open flame of any kind to test for leaks.**

# KEY DIMENSIONS AND COMPONENTS OF THE GAS CONNECTIONS

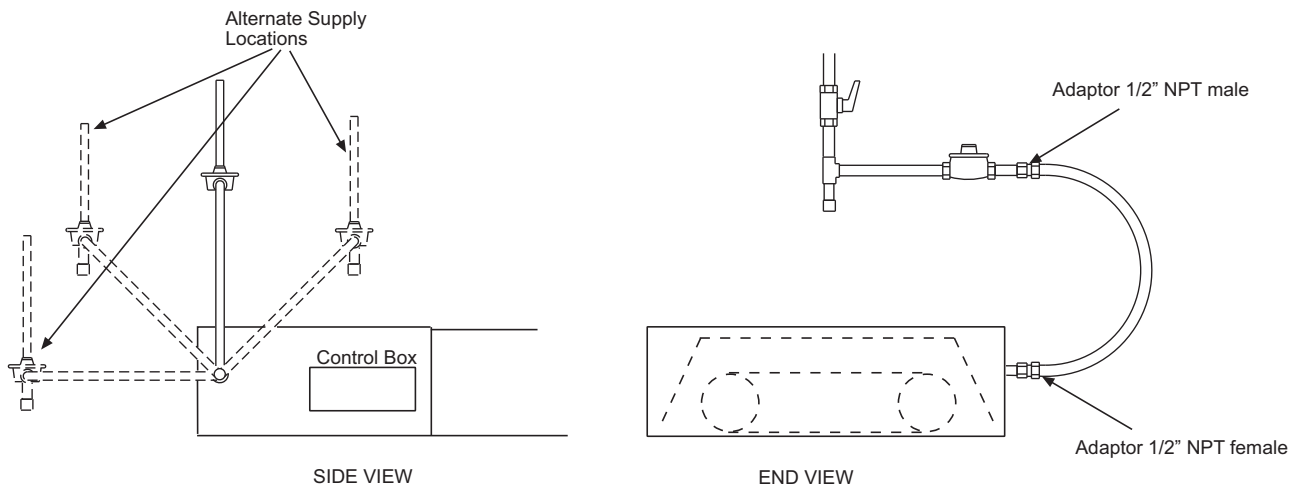
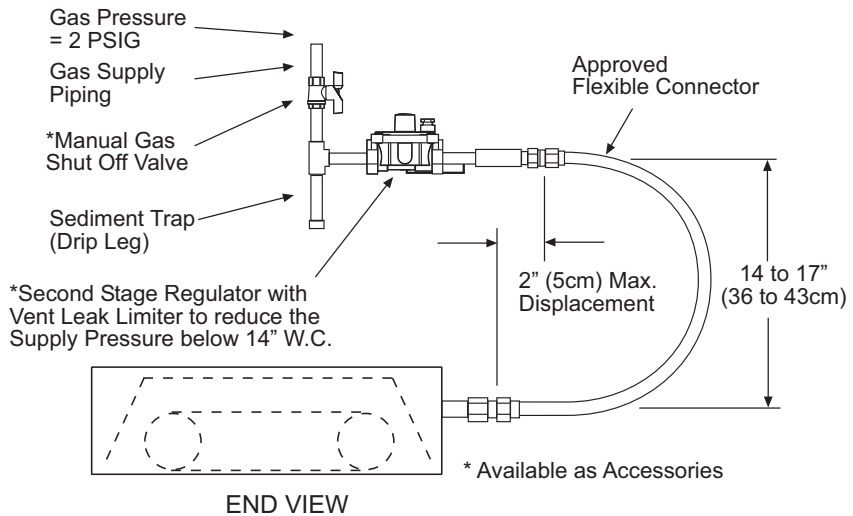

## INCORRECT POSITIONS

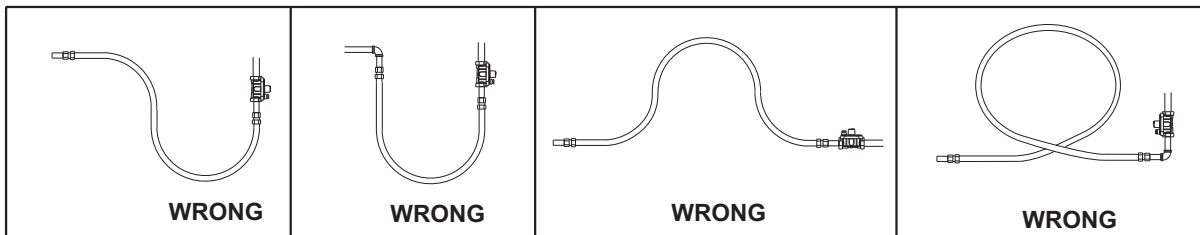



**⚠ WARNING**

**US ONLY: CONNECTOR MUST BE INSTALLED IN “S” CONFIGURATION. USE ONLY THE 36” LONG CONNECTOR THAT WAS FURNISHED WITH THIS HEATER.**

**US ONLY:** A gas connector certified for use on a tubular type infrared heater per the standard for Connectors for Gas Appliances, ANSI Z21.24/CSA 6.10 is supplied for installation in US only. The gas connector is 36” long and 1/2” nominal ID, and must be installed as shown above, in one plane, and without sharp bends, kinks or twists.

**CANADA ONLY:** A Type I hose connector should be used that is certified as being in compliance with the Standard for Elastomeric Composite Hose and Hose Couplings for Conducting Propane and Natural Gas (CAN/CGA 8.1) and is of length of 36+/- 6 in (90+/- 15 cm). The gas connector must be installed as shown above, in one plane, and without sharp bends, kinks or twists.

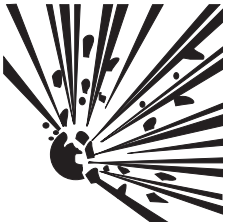
## 12.0) INSTRUCTIONS FOR PRESSURE TEST GAUGE CONNECTION

<b>⚠ WARNING</b>		
		<b>FIRE AND EXPLOSION HAZARD</b>
<p>Never operate the heater with the access panel open or removed.</p> <p>The access panel must be closed tightly during operation.</p> <p>Failure to do so may result in death, serious injury or property damage.</p>		

### SUPPLY PRESSURE

- The installer will provide a 1/8" N.P.T. tapped plug, accessible for test gauge connection immediately upstream of the gas supply connection to the heater.

### MANIFOLD PRESSURE - COMBINATION GAS VALVE IS FACTORY SET

- Turn the gas valve to the "OFF" position. Remove the 1/8" plug from the combination gas valve at the **Outlet Pressure Tap** shown below and connect a 1/8" nipple to the tapped hole. Connect the test gauge to the nipple. Turn on the gas supply.

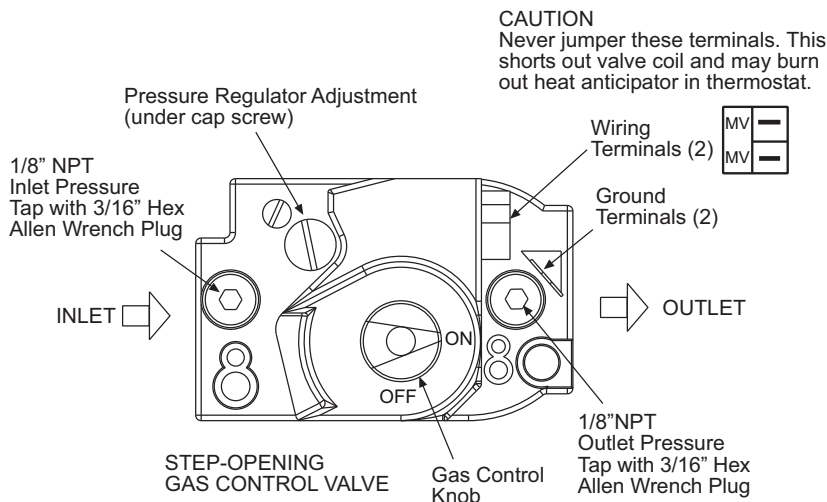

- With the main burner operating, check the burner manifold pressure using a water column manometer. Gauges that measure pressure in pounds per square inch are not accurate enough to measure or set the manifold pressure. All measurements **MUST BE** made when this heater and all other gas burning equipment that is connected to the gas supply system are operating at maximum capacity.
- The combination gas valve is factory set and should not require adjustment. If full rate adjustment is required, remove the cover screw. Using a small screwdriver, turn the adjustment screw clockwise  $\curvearrowright$  to increase or counterclockwise  $\curvearrowleft$  to decrease the gas pressure to the burner. Replace the cover screw. **NOTE: The step opening pressure of this gas valve is not adjustable.**
- Check the burner at step pressure, observing burner ignition and flame characteristics. The burner should ignite properly and without flashback to the orifice, and should remain lit.

<b>GAS PRESSURE TABLE</b>			
<b>GAS TYPE</b>	<b>MANIFOLD PRESSURE</b>	<b>SUPPLY PRESSURE</b>	
		<b>Minimum*</b>	<b>Maximum</b>
Natural Gas	3.5" W.C.	7" W.C.	14" W.C.
Propane Gas	10.0" W.C.	11" W.C.	14" W.C.

\* Minimum permissible gas supply pressure for purpose of input adjustment.



## 13.0) ELECTRICAL CONNECTIONS

### ⚠ WARNING



#### ELECTRIC SHOCK HAZARD

Disconnect electrical power and gas supply before servicing.

This appliance must be connected to a properly grounded electrical source.

Failure to do so may result in death or serious injury.

1. All electric wiring shall conform to the latest edition of the National Electrical Code (ANSI/NFPA No. 70), or the code legally authorized in the locality where the installation is made.
2. The unit must be electrically grounded in accordance with the National Electrical Code (ANSI/NFPA No. 70-latest edition). In Canada, refer to current standard C22.1 Canadian Electrical Code Part 1.
3. The wiring providing power to the heater shall be connected to a permanently live electrical circuit, one that is not controlled by a light switch.
4. The power supply to the unit should be protected with a fused disconnect switch or circuit breaker. A service switch, as required by local codes, shall be located in the vicinity of the heater (check local codes for allowable distances) and should be identified as Heater Service Switch. All electrical wiring must be located in accordance with the required Clearances to Combustibles from the heater as listed on the nameplate on the heater.
5. When connecting the **supply circuit** to the heater, wiring material having a minimum size of 14 AWG and a temperature rating of at least 90°C shall be used.

### INTERNAL CONNECTION WIRING DIAGRAM — Direct Spark Ignition

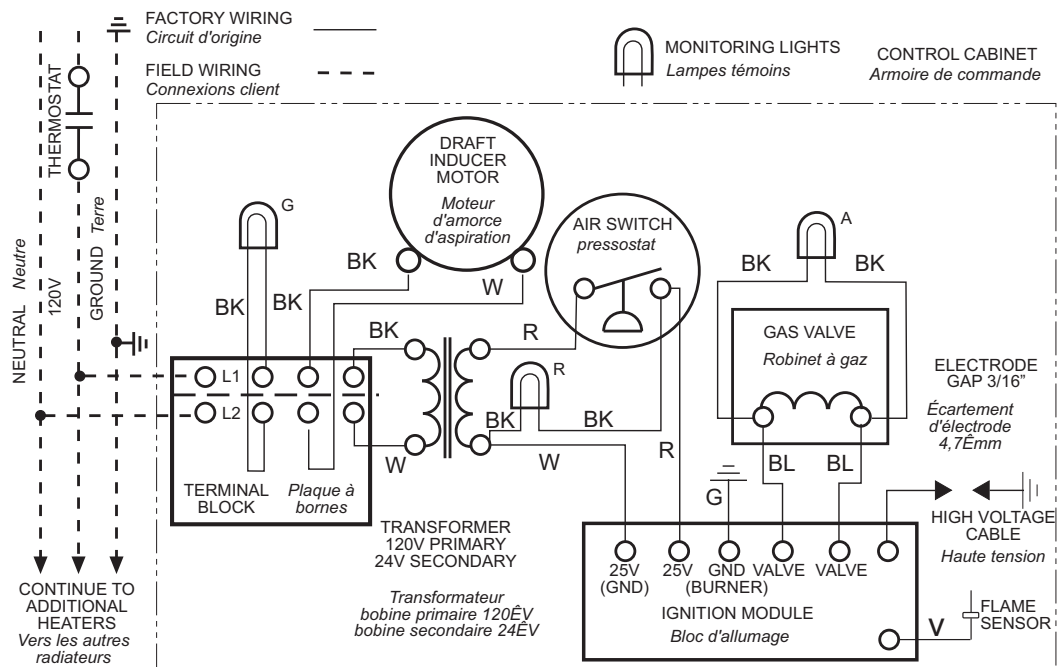

#### NOTES:

1. If any of the original wire as supplied with the appliance must be replaced, it must be replaced with wiring material having a temperature rating of at least 105°C. (18 Ga. CSA 600V Type TEW)
2. When connecting the supply circuit to the heater, wiring material having a minimum size of 14 AWG and a temperature rating of at least 90°C shall be used.
3. A replaceable 3-amp fuse (1-1/4" long) is fitted to the Ignition Control Module.

## SCHEMATIC WIRING DIAGRAM — Direct Spark Ignition

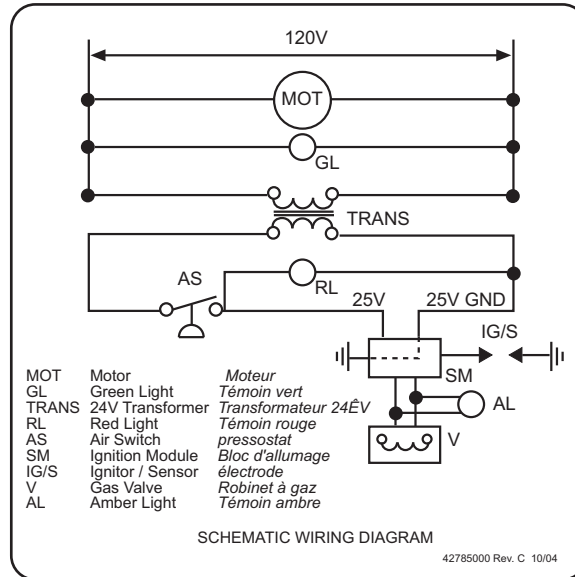

## FIELD CONNECTION AND THERMOSTAT WIRING DIAGRAMS

### A. LINE VOLTAGE (120V) THERMOSTAT CONNECTIONS – SINGLE HEATER PER THERMOSTAT

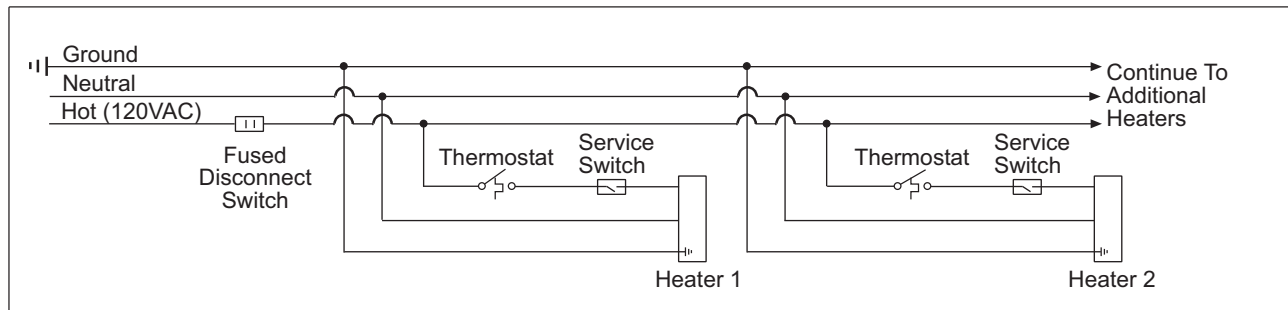

### B. LINE VOLTAGE (120V) THERMOSTAT CONNECTIONS – MULTIPLE HEATERS PER THERMOSTAT

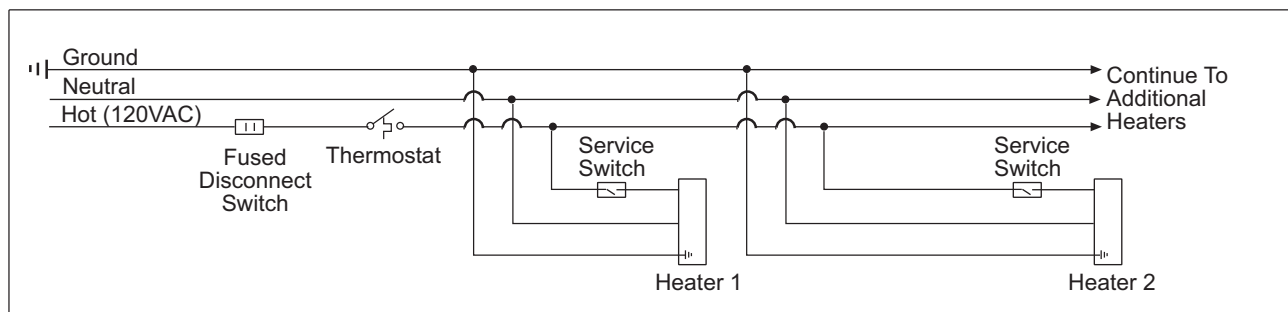

**C. LOW VOLTAGE (24V) THERMOSTAT CONNECTIONS – SINGLE HEATER PER THERMOSTAT**

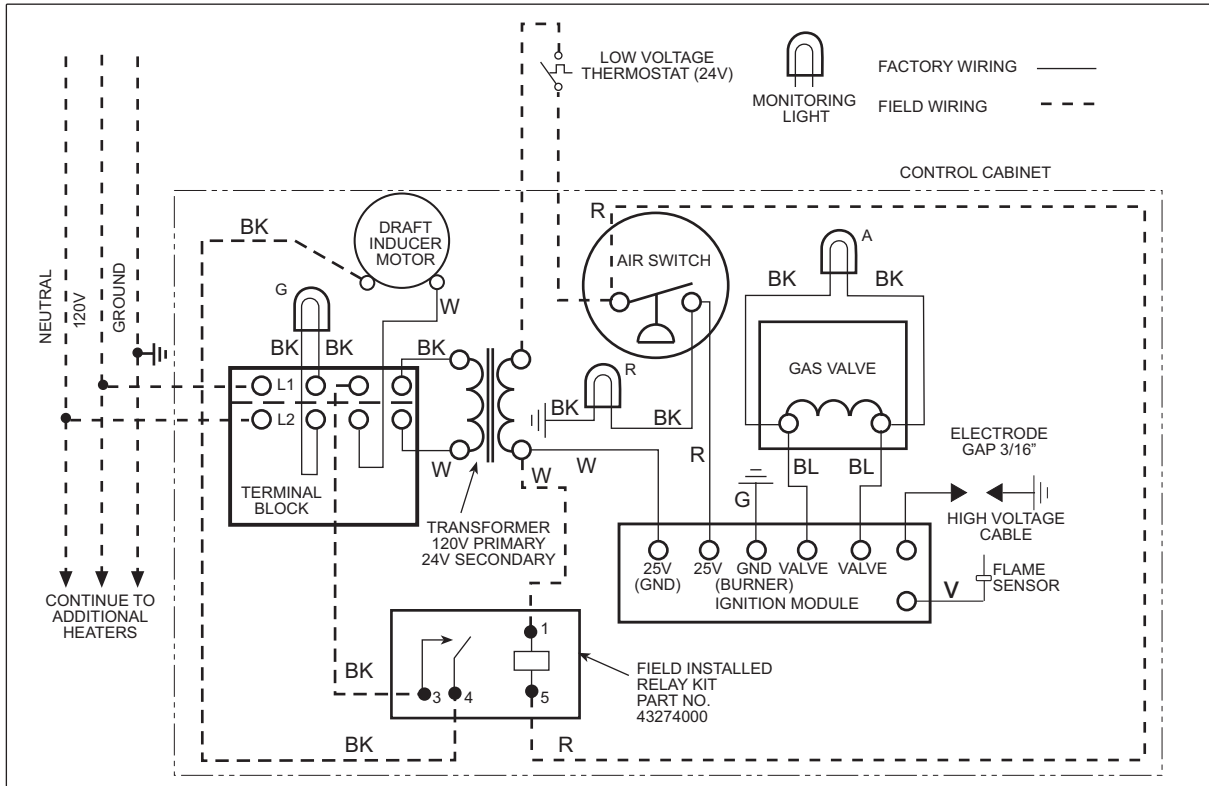

**Order 24V Relay Kit (Part No. 43274000) for Low Voltage (24V) thermostat connection.**

**NOTES:**

1. If any of the original wire as supplied with the appliance must be replaced, it must be replaced with wiring material having a temperature rating of at least 105°C. (18 Ga. CSA 600V Type TEW)
2. When connecting the supply circuit to the heater, wiring material having a minimum size of 14 AWG and a temperature rating of at least 90°C shall be used.
3. A replaceable 3-amp fuse (1-1/4" long) is fitted to the Ignition Control Module.

**D. LOW VOLTAGE (24V) THERMOSTAT CONNECTIONS – MULTIPLE HEATERS PER THERMOSTAT**

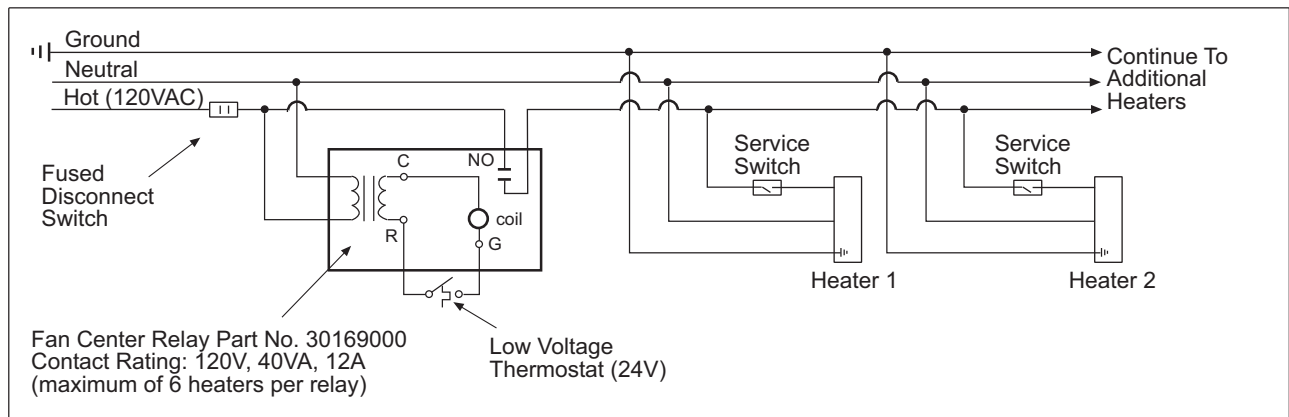

## 14.0) VENTING

### ⚠ WARNING

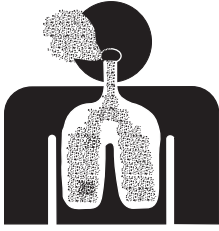

#### CARBON MONOXIDE HAZARD

Heaters installed in an unvented mode require a minimum ventilation flow of 4 CFM per 1,000 Btu/hr of total installed capacity.

In buildings with airborne contamination the heater must be installed with fresh air for combustion.

Failure to do so may result in death, serious injury, property damage or illness from Carbon Monoxide poisoning.

- A. BASIC FLUE VENTING** — Venting must comply with the latest edition of the National Fuel Gas Code (ANSI Z223.1-latest edition) or the authority having jurisdiction. Other venting references are in the equipment volume of the ASHRAE Handbook.

#### **SINGLE HEATER VENTING (VERTICAL THROUGH THE ROOF)**

1. When venting the heater to outside of building through a roof, use single-wall metal pipe. This is to be constructed of galvanized sheet metal or other approved noncombustible corrosion-resistant material as allowed by state or local codes.
2. A vent passing through a combustible roof shall extend through an approved clearance roof thimble. Double-wall, Type B vent must be used for the portion of the vent system which passes through the combustible roof. An approved vent cap must be attached to end of the flue.
3. The maximum equivalent length of vent pipe should be carefully observed. A safety switch in the heater is designed to shut the heater off before excessive flue restriction causes bad combustion. Refer to the Vent Sizing Table for vent pipe diameter.
  - Minimum Equivalent Length = 5 ft. of pipe
  - Maximum Equivalent Length = 100 ft. of pipeUse the following correction factors to obtain the equivalent length:
  - Subtract 15 ft. if the run is horizontal.
  - Subtract 10 ft. for an approved vent cap.
  - Subtract 10 ft. for each elbow beyond 15 ft. from the heater.
  - Subtract 15 ft. for each elbow within 15 ft. of the heater.
4. Joints between sections of piping shall be fastened by sheet metal screws or other approved means and should be sealed to prevent leakage of flue gas into building. Aluminum or Teflon tape suitable for 550°F (3M Company tapes 433 or 363) or silicone sealant is recommended.
5. Avoid locating elbows in the first 5' of vent pipe whenever possible. Limit to (2) 90° elbows. When vent pipe is in a horizontal run, it must have 1/4 inch per foot rise.
6. All portions of the vent pipe shall be supported to prevent from sagging (6' spacing is recommended).
7. When the vent pipe passes through areas where the ambient temperature is likely to induce condensation of the flue gases, the vent pipe should be insulated and a condensation drain should be provided.
8. Minimum clearance for single-wall flue pipe to combustible material shall be 6 inches. This may be reduced when the combustible material is protected as specified in the National Fuel Gas Code or the authority having jurisdiction.
9. Single-wall metal pipe shall not originate in any unoccupied attic or concealed space and shall not pass through any attic, inside wall or concealed space, or through any floor. For the installation of a single-wall metal pipe through an exterior combustible wall, refer to latest edition of the National Fuel Gas Code or the authority having jurisdiction.
10. A venting system shall terminate at least 3 ft. above any forced air inlet located within 10 ft.

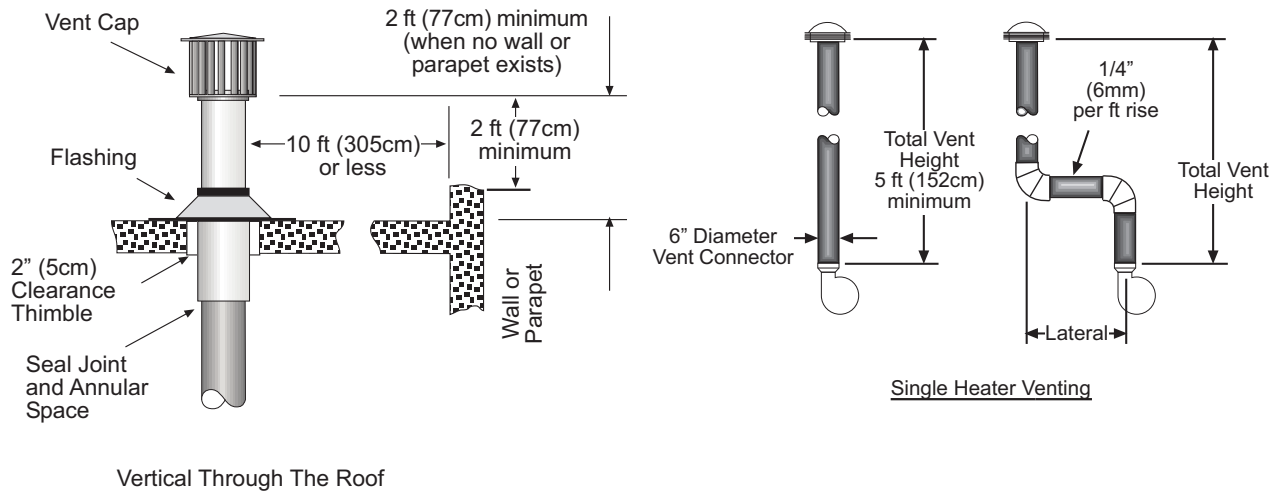

**SINGLE HEATER VENTING (HORIZONTAL THROUGH SIDEWALL)**

When venting the heater horizontally through a combustible outside sidewall, the same requirements listed previously for venting **Vertical Through The Roof** apply except as follows:

1. A vent passing through a combustible wall must pass through an approved clearance thimble (Air-Jet #4VT or Ameri-Vent #4EWT or other thimbles) that are listed by a nationally recognized testing agency. Double-wall Type B vent must be used for the portion of the vent system which passes through the combustible sidewall.
2. An approved vent cap (Braidert or equal) must be attached to the end of the vent pipe.
  - Minimum Equivalent Length = 5 ft. of pipe
  - Maximum Equivalent Length = 75 ft. of pipe

**NOTE:** To minimize problems associated with condensation in long horizontal runs, vent pipe can be insulated.

3. When venting through a sidewall, the horizontal vent pipe shall rise not less than 1/4 inch per foot from the start of the vent system to the vent terminal. All portions of the vent pipe shall be supported to prevent sagging. (6' spacing is recommended)
4. A minimum clearance of 6 inches must be maintained between the outside wall and vent cap (18" clearance will provide stability under high wind conditions).
5. The horizontal venting system shall not terminate:
  - Less than 4 ft. (1.2m) below, 4 ft. (1.2m) horizontally from or 1 ft. (30cm) above any door, operable window or gravity air inlet into any building. The bottom of the vent terminal shall be located at least 7 ft. (2.1m) above grade or above snow accumulation level as determined by local codes.
  - Less than 3 ft. (0.9m) from a combustion air inlet.
  - Less than 3 ft. (0.9m) from any other building opening or any gas service regulator.
  - Less than 7 ft. (2.1m) above public walkways.
  - Directly over areas where condensate or vapor could create a nuisance or hazard or be harmful to the operation of gas utility meters, regulators, relief valves, or other equipment. Building materials should be protected from flue gases and condensate.
  - Less than 12" (0.30m) when directly below a combustible overhang.
6. In regions of the country where prevailing winds are consistently higher than 40 mph, it may be necessary to terminate the vent system above the roof level.

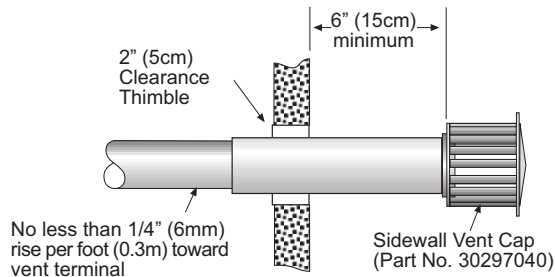

Horizontal Through Sidewall

## **MULTIPLE HEATER VENTING (CONNECTIONS INTO A COMMON VENT OR MANIFOLD)**

Requirements for venting of multiple heaters are the same as described for **SINGLE HEATER VENTING** except as follows:

1. The common vent size and total vent height is normally determined by the number of heaters per common vent, length of horizontal connector runs, and connector rise. Connector lengths should be as short as possible and have a minimum 1/4 inch per foot rise. Without regard to connector rise and total vent height due to many possible venting configurations, the following should be observed:
  - Common vent pipe & vent connector diameter should be no less than that shown in the following Vent Sizing Table.
  - The connector length should be no more than 75% of the vertical portion of vent above the connector.
  - Where possible, use a Y-connector to the common vent.
2. Material for connectors should be constructed of galvanized sheet metal or other approved noncombustible corrosion resistant material as allowed by state or local codes. All common vent pipe should be insulated flue pipe or double-wall, Type B vent.
3. Avoid unnecessary bends. Limit to two (2) 90° elbows.
4. The entire length of vent connector shall be readily accessible for inspection, cleaning and replacement.
5. Groups of heaters with a common vent must be controlled by a common thermostat.

### **⚠ WARNING**

**Common venting of multiple heaters in confined spaces is prohibited. If any heater connected to a common vent system for multiple heaters is found inoperative, the heater should be disconnected from the vent system and its entrance into the vent system capped.**

#### Multiple Heater Vertical Venting Arrangement

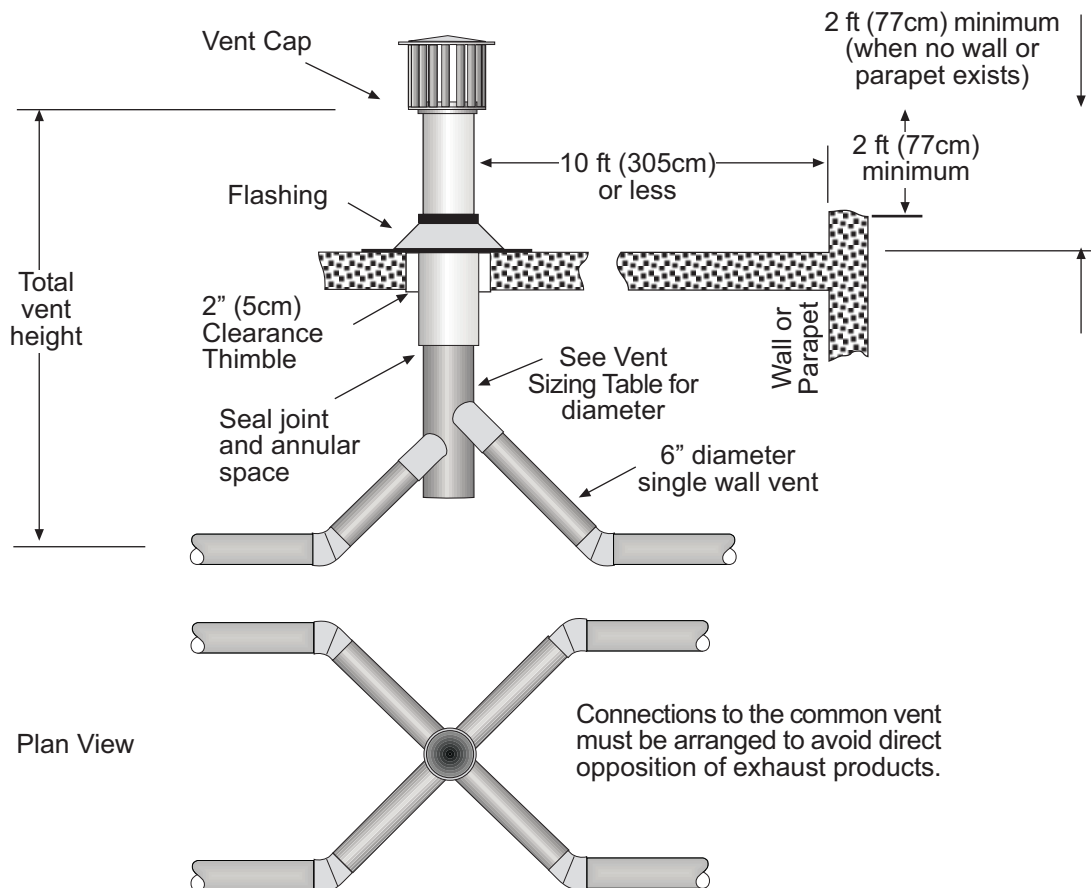

**Multiple Heater Horizontal Venting Arrangement**

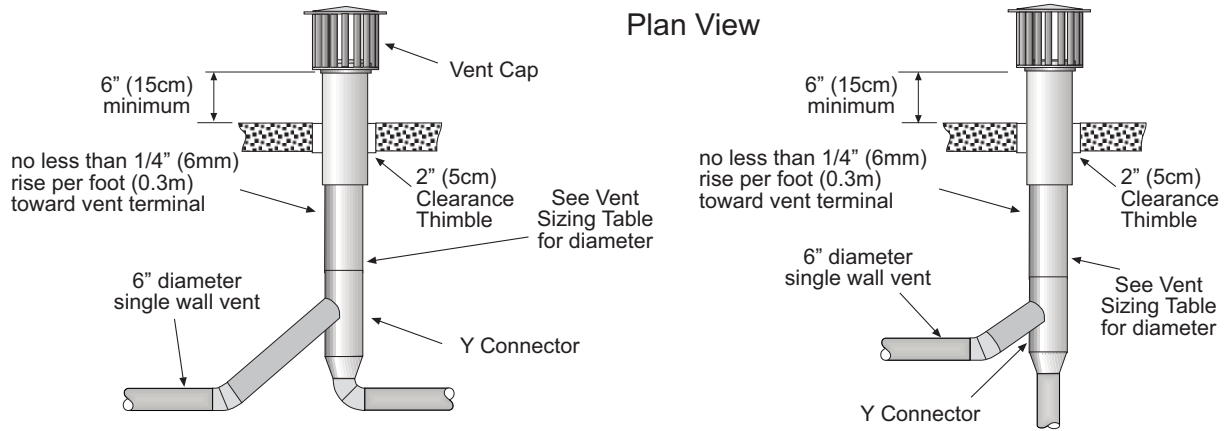

**Multiple Heater Venting (Connections into a Manifold)**

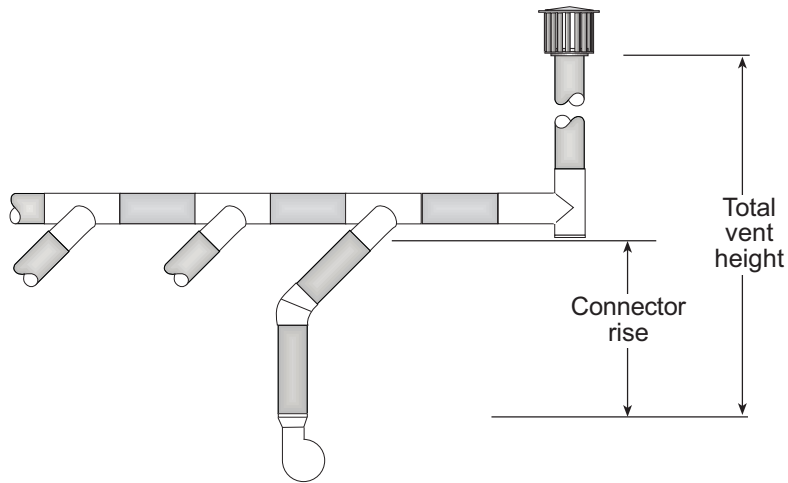

<b>VENT SIZING TABLE — Multiple Heater Venting</b>							
	<b>Number of Heaters</b>						
	<b>1</b>	<b>2</b>	<b>3</b>	<b>4</b>	<b>5</b>	<b>6</b>	<b>8</b>
<b>RSTP15 and RSTP17</b>	<b>6"</b>	<b>8"</b>	<b>10"</b>	<b>11"</b>	<b>12"</b>	<b>12"</b>	<b>14"</b>
<b>COMMON VENT DIAMETER</b> (If a size is not available use the next larger size.)							

THE ABOVE ILLUSTRATIONS AND TABLE OF VENT SIZES FOR COMMON VENTING OF MULTIPLE HEATERS ARE IN ACCORDANCE WITH THE NATIONAL FUEL GAS CODE ANSI Z223.1-LATEST EDITION, NFPA 54-LATEST EDITION, EQUIPMENT VOLUME OF 1988 ASHRAE HANDBOOK, CURRENT CAN/CGA-B149.1/2-M86 INSTALLATION CODE, AND AGA PUBLICATION NO. 10M5.85 2.5-2 ON FUNDAMENTALS OF GAS APPLIANCE VENTING AND VENTILATION-REVISED BUT ARE NOT A PART OF THE CSA CERTIFICATION.

- B. INDIRECT VENTING (UNVENTED HEATERS)** — This heater requires ventilation in the building to dilute the products of combustion and provide fresh air for efficient combustion. Where unvented heaters are used, gravity or mechanical means shall be provided to supply and exhaust at least 4 CFM per 1,000 Btu/hr input of installed heaters. Exhaust vents must be located at the highest point above and in the vicinity of the heaters, and the inlet vents must be located below the level of the heaters. An exhaust hood must be used as described in Section 10.0). **NOTE:** Exhaust Hoods are supplied as Accessory items.

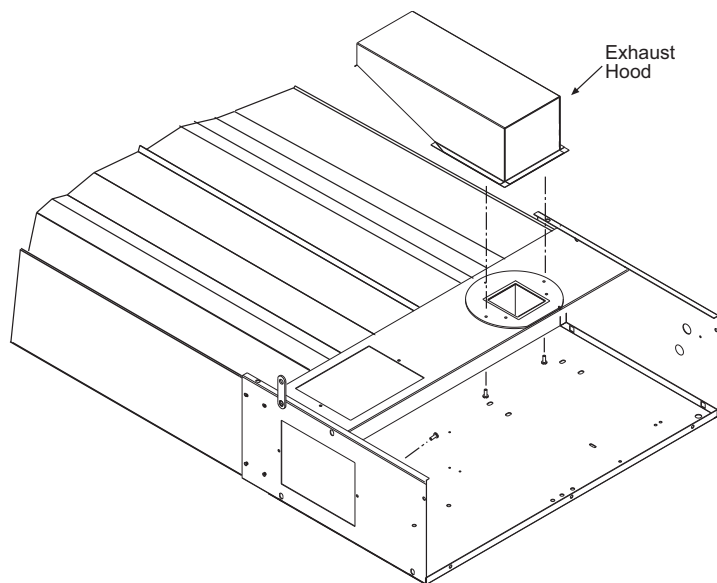

## 15.0) AIR FOR COMBUSTION

If indoor combustion air is to be supplied for a tightly enclosed area, one square inch of free area opening shall be provided below the heater for each 1,000 Btu/hr of heater input. Adequate clearances around the air inlet screen must be maintained at all times. In larger open areas of buildings, infiltration normally is adequate to provide air for combustion.

### 15.1) DIRECT OUTSIDE AIR FOR COMBUSTION

Outside combustion air should be supplied directly to the heater when the building is subject to negative pressure, or when contaminants or high humidity are present in the building air. These contaminants include paints, solvents, corrosive vapors or any other foreign particles that may cause damage to the heater or result in poor combustion.

Outside combustion air can be brought directly to the heater by a 6" diameter duct less than 50 ft. long or equivalent (see table in Section 14.0). This is attached to the 6" diameter starting collar. The starting collar is fitted to the top of the control box cabinet **after first removing and discarding the perforated cover and installing an adapter plate (Part #42783000)**. Alternately the combustion air can be brought from the side, after replacing the solid cover panel on the side with an adapter plate, and replacing the perforated cover panel on the top with the solid cover panel from the side. An approved vent cap must be placed directly on the end of the outside combustion air inlet pipe. The combustion air inlet should be not less than 3 ft. (0.9m), either vertically or horizontally, from the flue vent termination. The air intake terminal must be located not less than 1 ft. (30cm) above grade. It is good installation practice to supply combustion air from the same pressure zone as the vent outlet. Avoid bringing combustion air to the heater from an attic space. There is no guarantee that adequate combustion air will be supplied.

In colder climates, where necessary, insulate the outside combustion air duct. Avoid locating the outside combustion air duct directly above the control box. Provide a capped cleanout T as necessary. In high humidity applications, the control box should be sealed with silicone sealer.

In **multiple heater applications**, the combustion air intake may be ducted individually or common ducted in the same configuration as shown for venting in Section 14.0). For combustion air intake duct sizing, please refer to the **Vent Sizing Table** and use the diameter indicated, based on the number of heaters per duct.



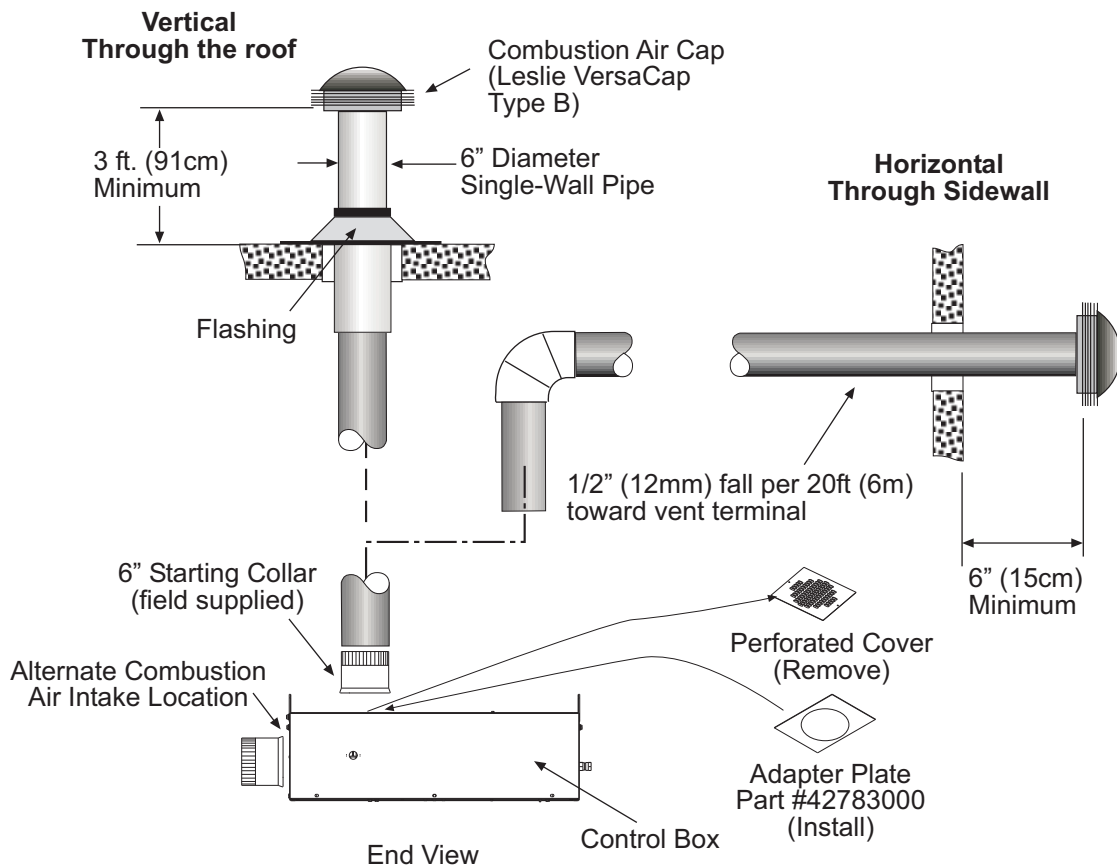
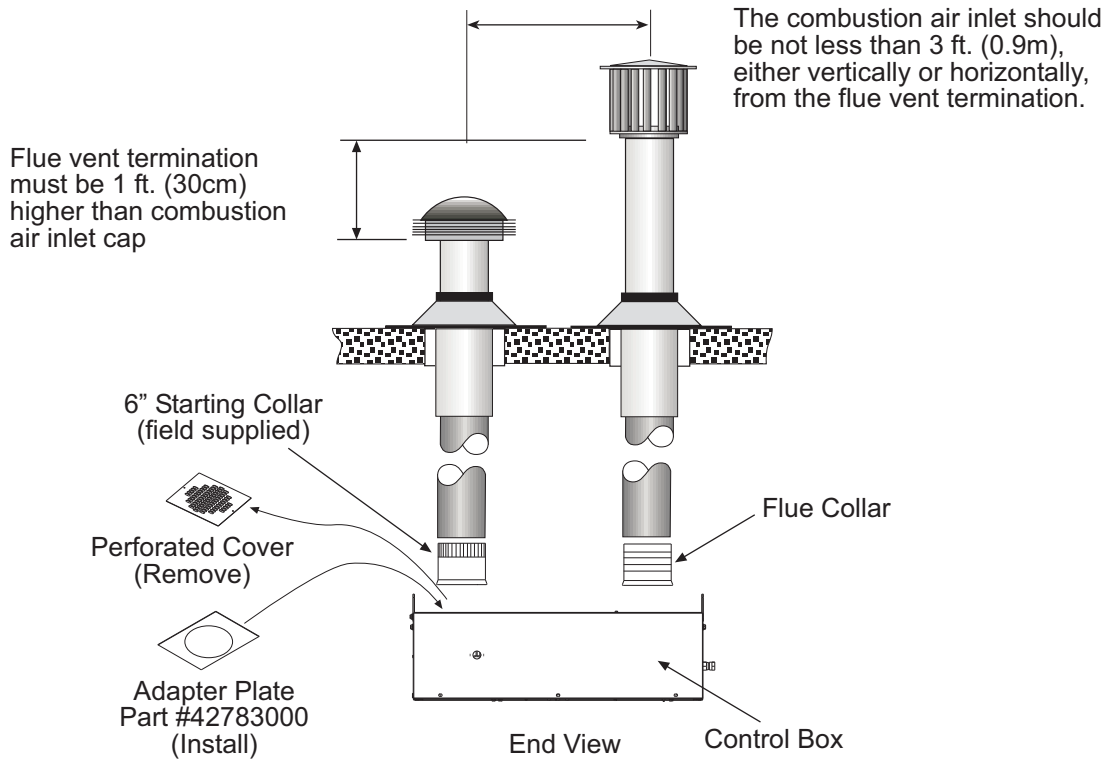



To bring outside combustion air to the heater, you will need to order the **RSTP Fresh Air Kit (Part #42782000)**, which includes one adapter plate. Refer to installation instruction below.

**INSTALLATION INSTRUCTIONS – RSTP FRESH AIR KIT – Part #42782000**

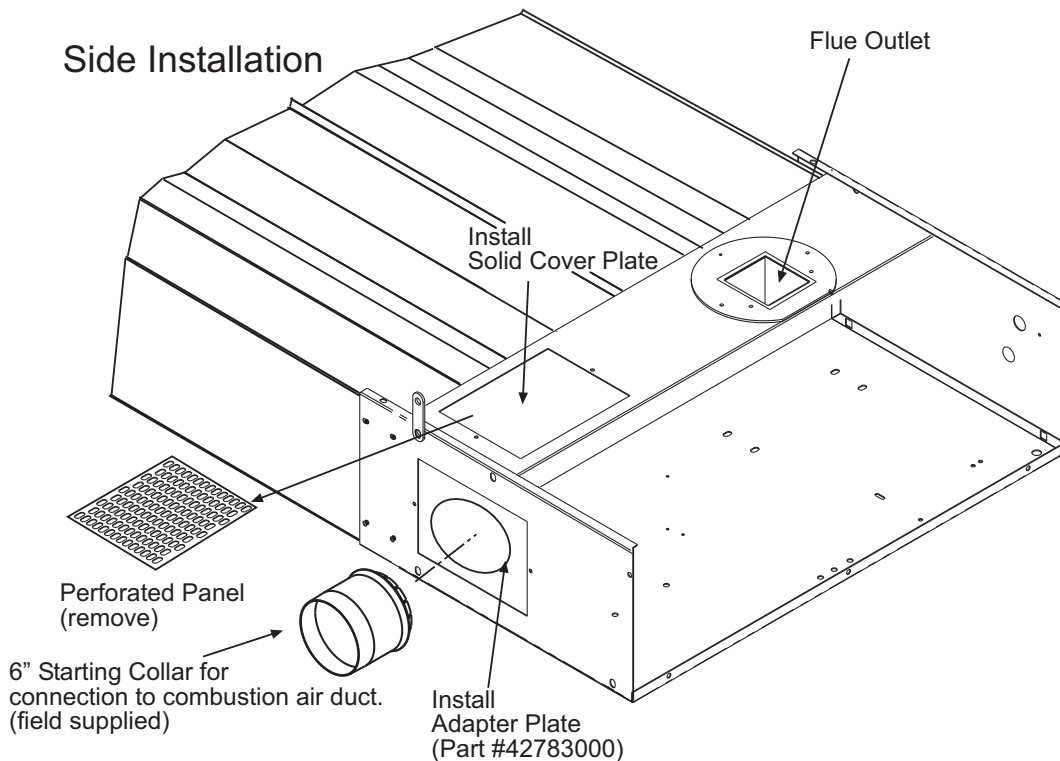
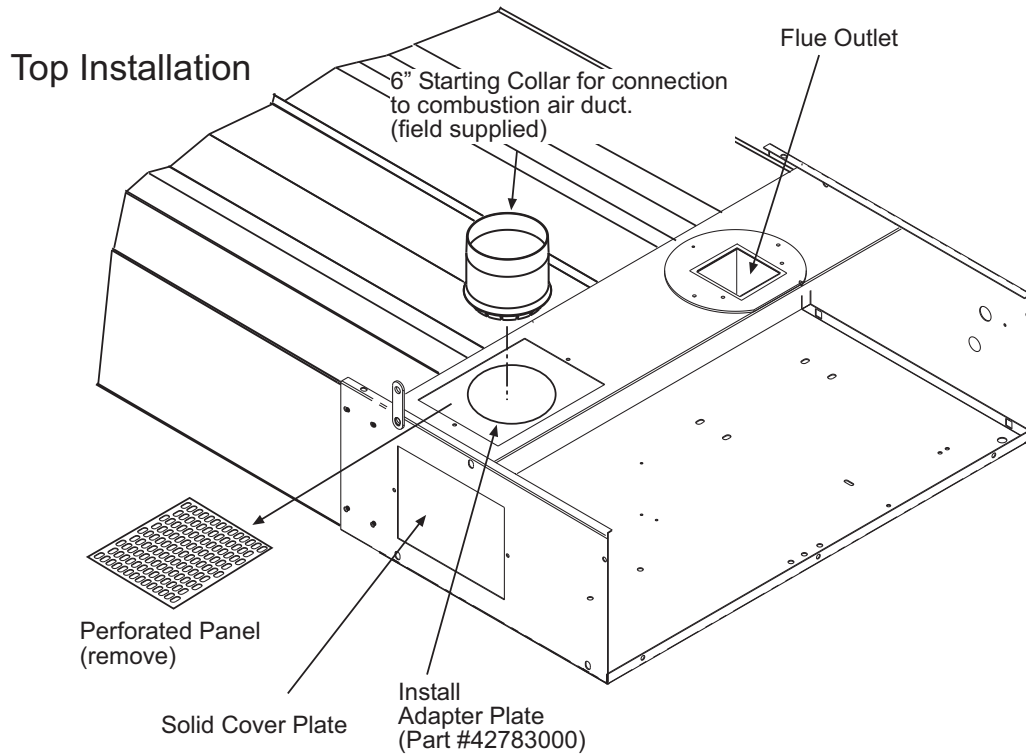
1. Remove the existing perforated panel from the top of the heater and replace it with the adapter plate from the Fresh Air Kit.
2. Insert a 6" starting collar (field supplied) and bend over the tabs to secure. Install the 6" diameter duct (not supplied) and vent cap per guidelines above.

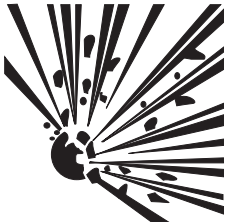

## 16.0) LIGHTING AND SHUTDOWN INSTRUCTIONS

⚠ WARNING		
		<h3 style="margin: 0;">FIRE AND EXPLOSION HAZARD</h3> <p>Never operate the heater with the access panel open or removed.</p> <p>The access panel must be closed tightly during operation.</p> <p>Failure to do so may result in death, serious injury or property damage.</p>

1. Turn on the gas and electrical supply. Rotate the gas valve knob counter-clockwise ⤴ to the “ON” position.
2. Set the thermostat to call for heat. The blower motor will energize.
3. Ignition should occur after the 30-second air pre-purge.
4. If ignition fails, the unit will spark for approximately 21 seconds and go into safety lockout. Turn the thermostat (power) off for 60 seconds to take the system out of lockout.
5. If the heater does not light, manually reset the thermostat or shut off power completely for 5 minutes before attempting to relight.
6. To permanently shut down the heater, rotate the gas valve knob clockwise ⤵ to the “OFF” position and turn off the gas and electrical supply.

**NOTE: The lighting and shutdown instructions are also shown on the permanent nameplate label attached to the heater control box.**

## 17.0) SEQUENCE OF OPERATION

The chart below shows the sequence of operation for the normal operating cycle.

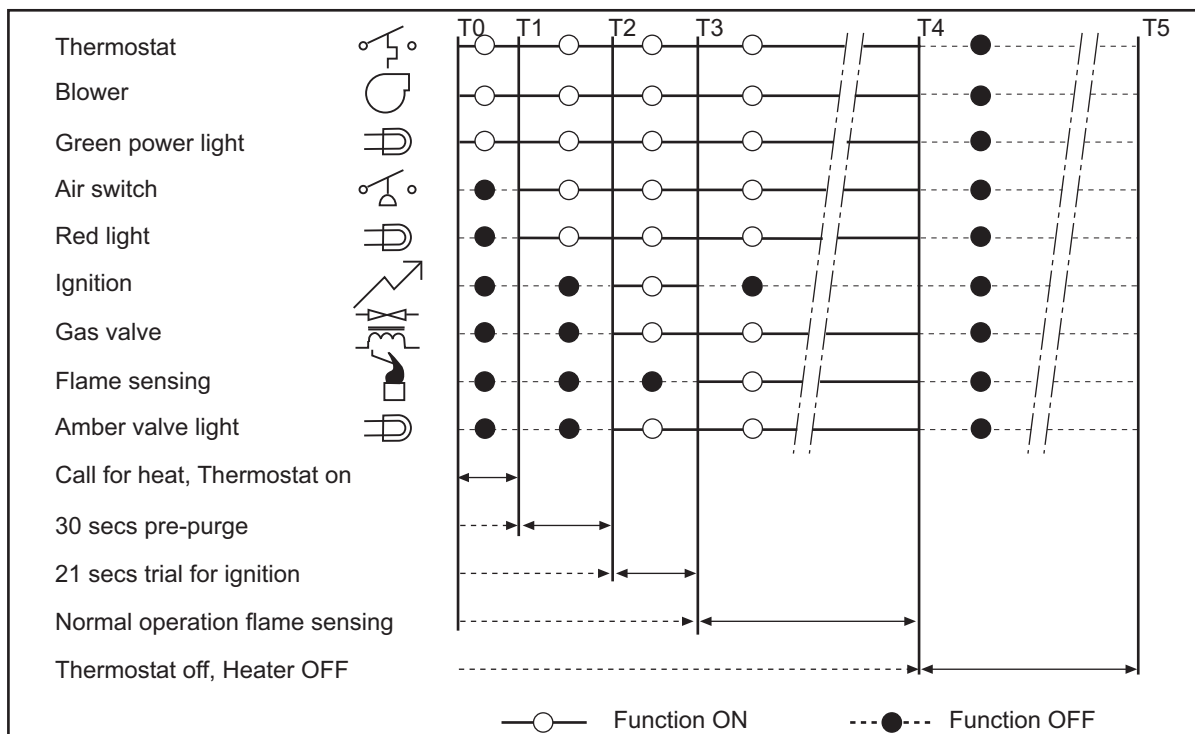

If the flame is not sensed during sequence T3 then the burner will automatically begin ignition sequence T2. If the flame is not re-established the heater will go to lockout.

## 18.0) CONTROL COMPONENT LOCATION

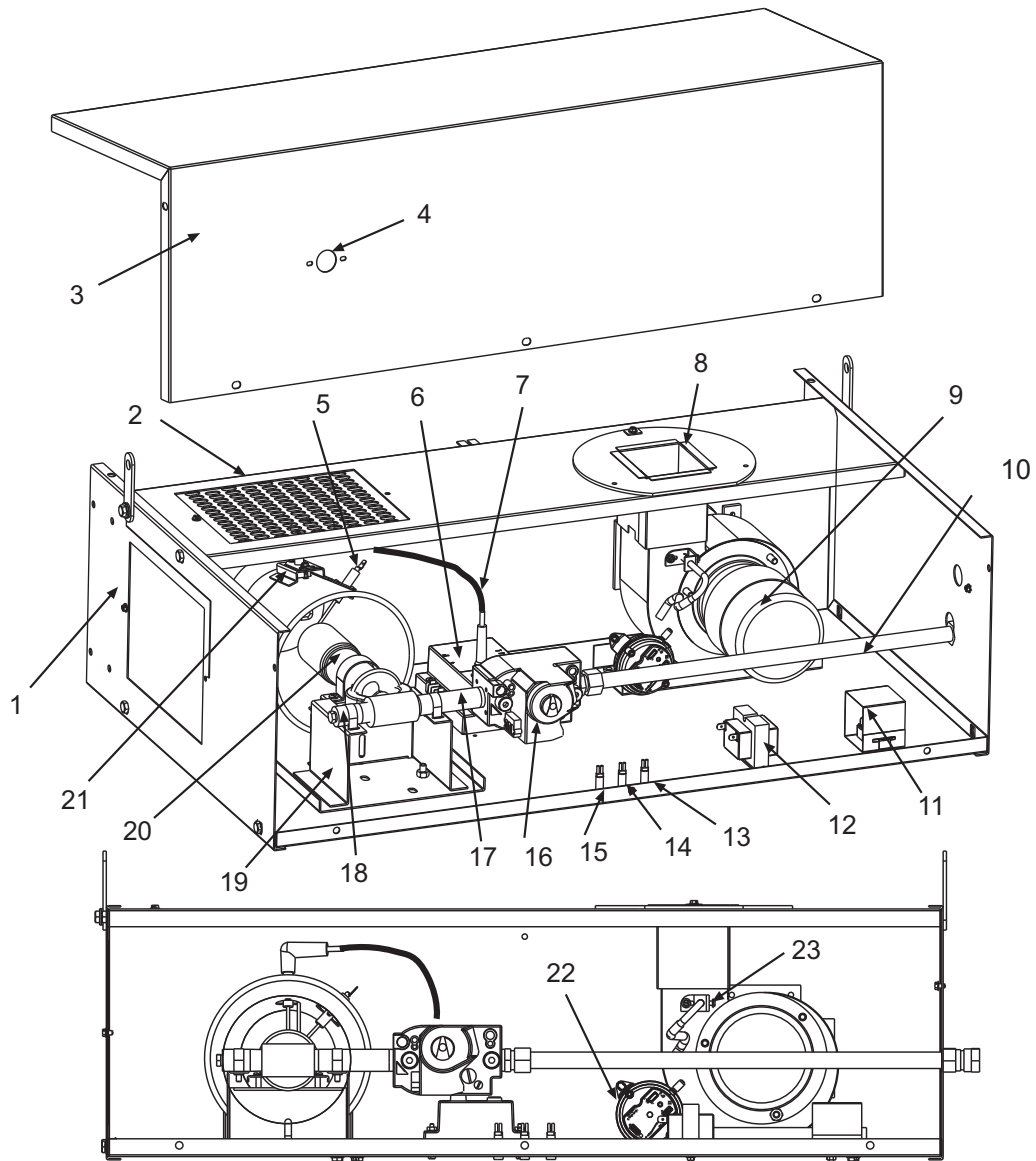

1	Cabinet Assembly	13	Monitoring Light, Green
2	Air Inlet Plate	14	Monitoring Light, Red
3	Access Panel	15	Monitoring Light, Amber
4	Sight Glass	16	Gas Valve
5	Flame Sensor	17	Nipple
6	Ignition Module	18	Nipple and Plug
7	Ignition Cable (partially shown)	19	Entrance Cone & Support Assembly
8	Flue Outlet	20	Main Burner
9	Draft Inducer	21	Spark Electrode
10	Manifold Tubing	22	Air Switch
11	Terminal Block and Shield	23	Air Sensing Probe
12	Transformer (120/24 VAC)		

## 19.0) CLEANING AND ANNUAL MAINTENANCE

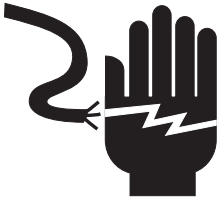
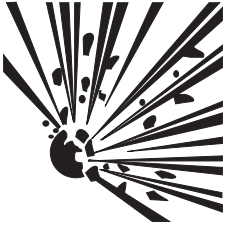
<b>⚠ WARNING</b>		
		<p style="text-align: center;"><b>ELECTRIC SHOCK &amp; EXPLOSION HAZARD</b></p> <p>Disconnect electrical power and gas supply before servicing.</p> <p>Failure to do so may result in death or serious injury.</p>

This heater must be cleaned and serviced annually by a qualified contractor before the start of each heating season and at any time excessive accumulation of dust and dirt is observed. Maximum heating efficiency and clean combustion will be maintained by keeping the heater clean.

The contractor shall check the following during periodic maintenance.

- **Clearances to combustibles:** Check that clearances are being maintained. Make sure there are no flammable objects, liquids or vapors near the heater. See also Section 4.0).
- **Reflectors:** Reflectors should be kept clean, at a minimum blow off the reflectors. (Dirty reflectors may reduce heat output).
- **Heat exchanger tubes:** Inspect the heat exchanger tubes to make sure they are not cracked, sagging or showing signs of fatigue. Check that the U bend is secured to the tubes.
- **Combustion air intake:** Disconnect combustion air intake from the control box and inspect internally using a flashlight to make sure no foreign material has collected in the tubes and that there is no obstruction around the air intake openings. Clean any foreign materials. Inspect any joints to make sure they are completely sealed. See also Section 15.0).
- **Venting system:** Disconnect vent pipe and inspect internally using a flashlight to make sure no foreign material has collected in the pipes. Check the external vent cap and make sure that there is no obstruction around the exhaust openings. Clean any foreign materials. Inspect any joints to make sure they are completely sealed. See also Section 14.0).
- **Gas lines:** Make sure that the gas lines are not leaking. Check the gas connection to the heater for any signs of damage, fatigue or corrosion. If there are any signs of damage to the gas connection or leaks found in the gas piping, immediately stop using the heater until the gas pipe and connections have been repaired or replaced. Check that the gas lines are not bearing the weight of the heater. See also Section 11.0).
- **Control box:** In order to extend the longevity of the heater, the heat exchanger tube and the burner must be level. Check that the control box is level. See also Section 9.0).
- **Blower wheel and housing:** Check that the blower wheel spins freely, blow out any dust or dirt with compressed air.
- **Electrode condition:** Visually check that the electrode gap is maintained at 3/16" and that the tips of the spark electrode are free from deposits. Clean off any deposits. Check that the electrode ceramic is free from cracks.
- **Suspension system:** Check that the suspension system is holding the heater level. Make sure that the heater is hanging securely, look for any evidence where the heater may have been hit accidentally and tighten any loose hanging points. Check that S hooks are closed. Check that there is no evidence of wear on the chain at the connection to the heater and at the ceiling.
- **Main burner and orifice:** Check the main burner and orifice; remove any dirt or debris including spider webs.

# 20.0) TROUBLESHOOTING GUIDE

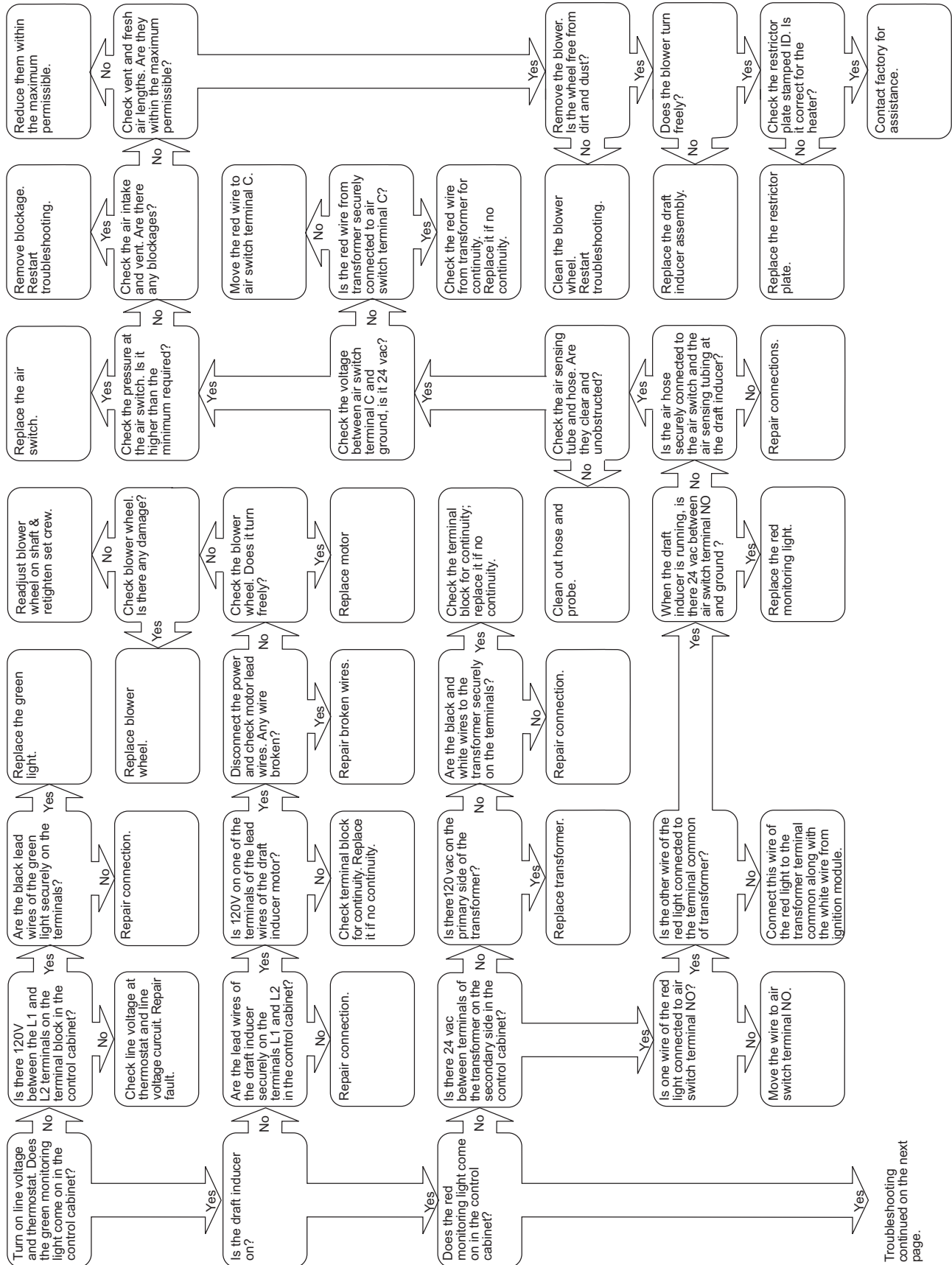

Troubleshooting continued on the next page.

Troubleshooting continued from the previous page.

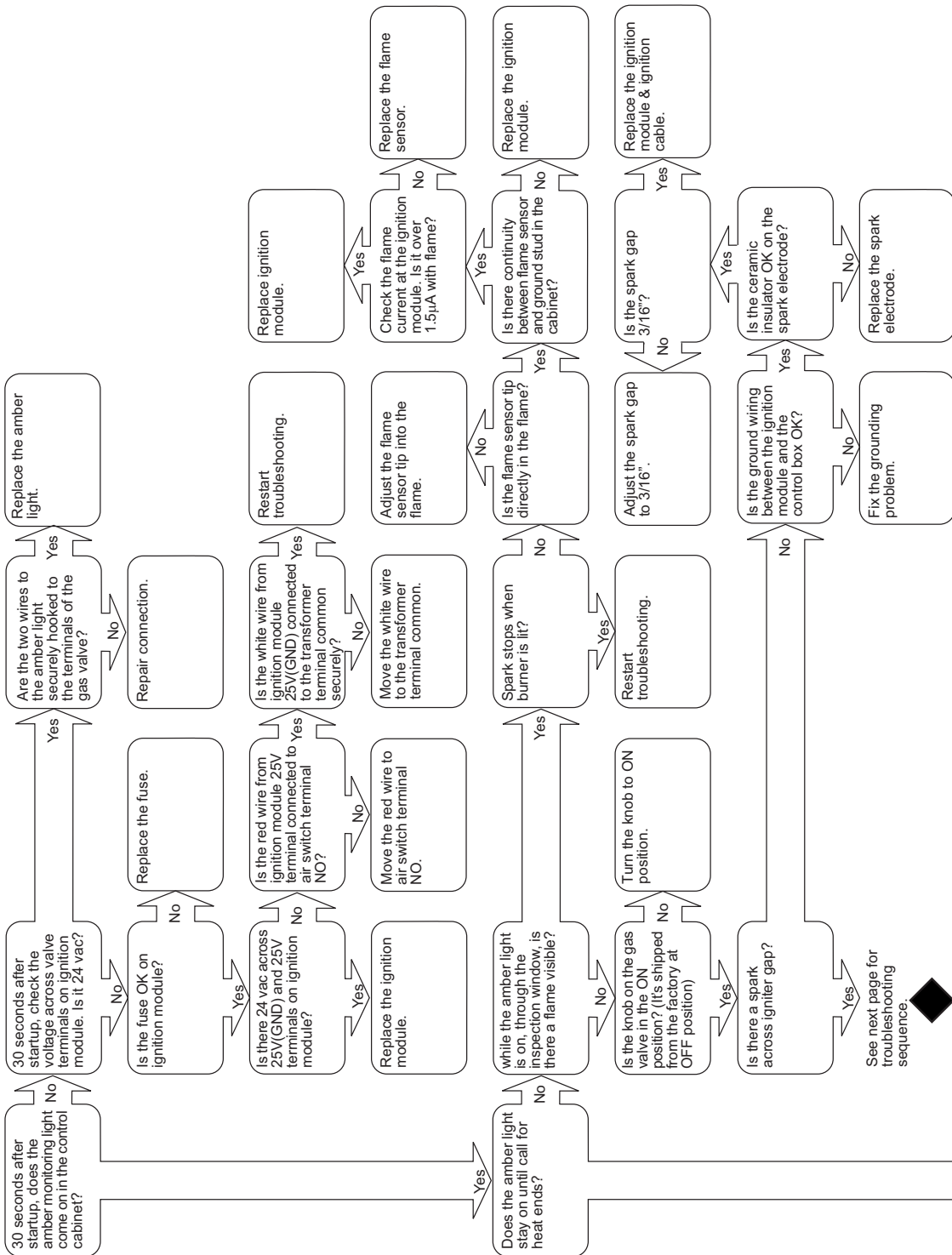

See next page for troubleshooting sequence.



Troubleshooting continued on the next page.

Troubleshooting continued from the previous page.

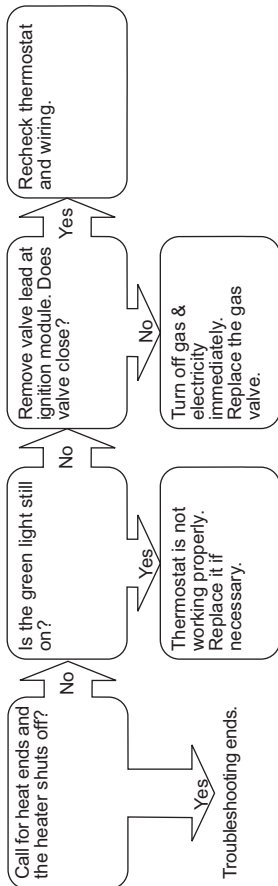

Troubleshooting continued from the previous page.

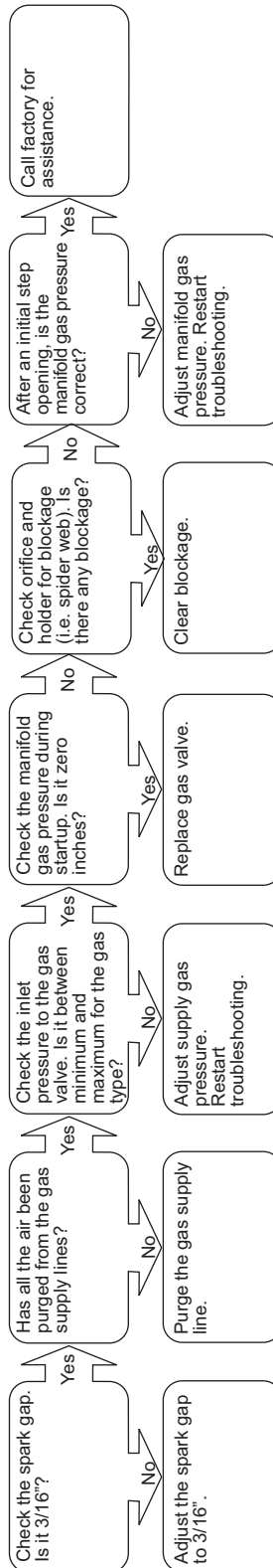



## 21.0) REPLACING PARTS

### ⚠ WARNING

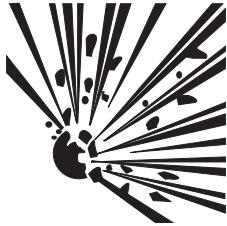

#### ELECTRIC SHOCK & EXPLOSION HAZARD

Disconnect electrical power and gas supply before servicing.

Failure to do so may result in death or serious injury.

Only use genuine Space-Ray replacement parts. Parts are available from the factory for replacement by a licensed person. Refer to the Replacement Parts Guide in Section 23.0) for all replacement parts.

## 21.1) REMOVAL OF SPARK ELECTRODE AND FLAME SENSOR

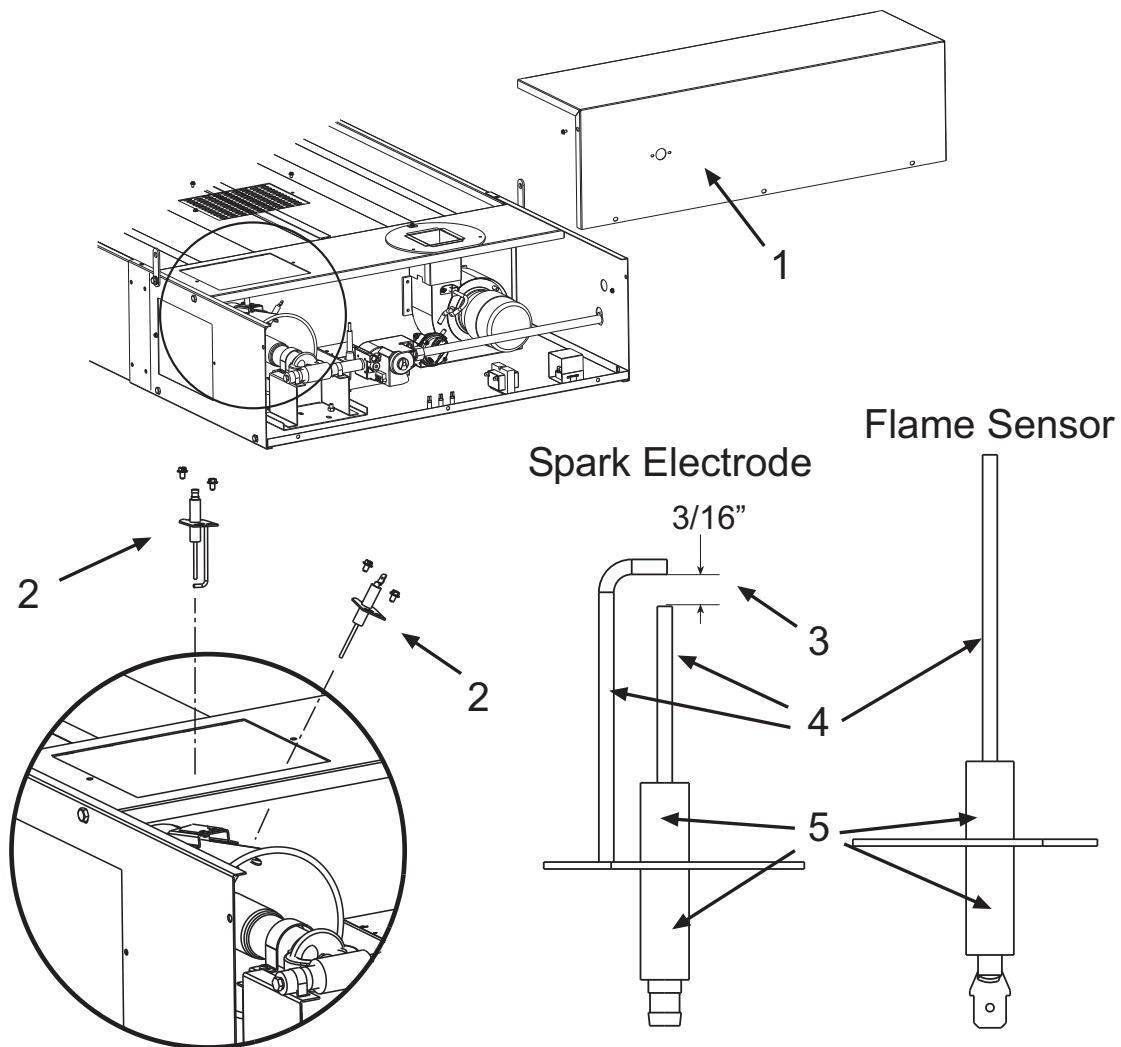

1. Disconnect electrical supply, open access panel.
2. Remove two mounting screws for each and take out the spark electrode and flame sensor.
3. Check that the spark gap is 3/16".
4. Check spark electrode and flame sensor. The rods should be clean and free from debris.
5. Check ceramic on the spark electrode and flame sensor. It should be free from cracks.

## 21.2) REMOVING MAIN BURNER AND GAS VALVE

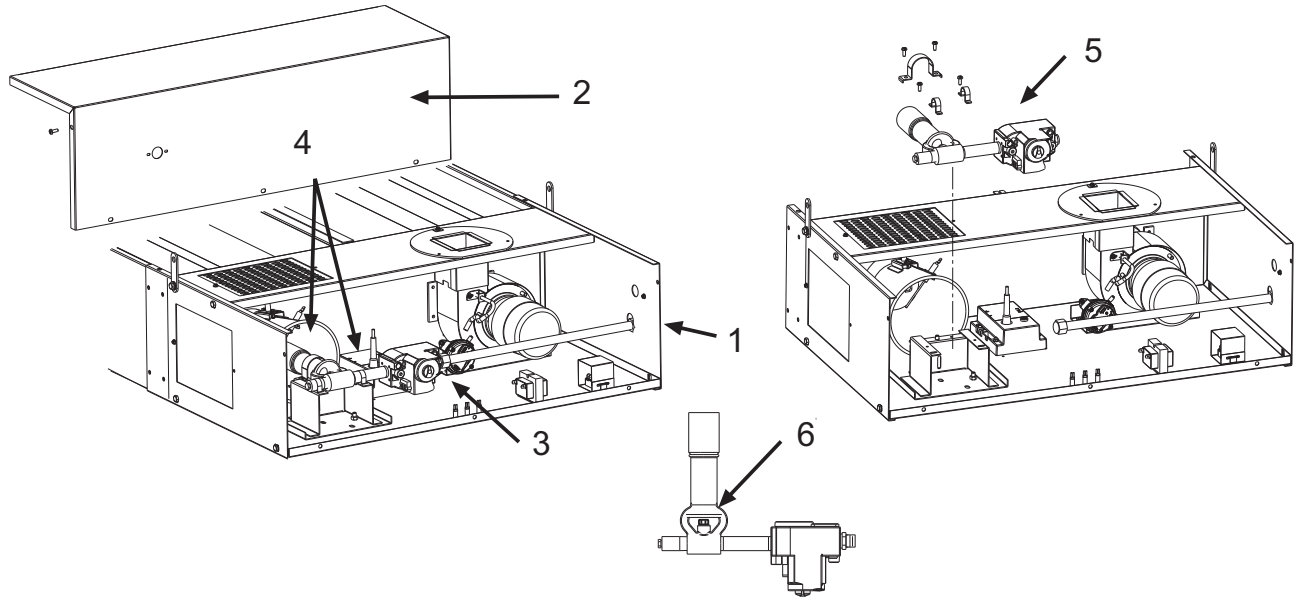

1. Disconnect electrical supply and gas connection from control box.
2. Remove the access panel and disconnect the wires from gas valve.
3. Disconnect the nut and sleeve from the gas valve compression fitting.
4. Remove screws, large burner clamp and both small manifold clamps from the manifold support.
5. Lift complete burner and gas valve assembly from the heater.
6. Check the orifice. If the gas valve is to be replaced, the pipe joint compounds must be resistant to the action of liquefied petroleum gases.

## 21.3) AIR SWITCH PRESSURE CHECK

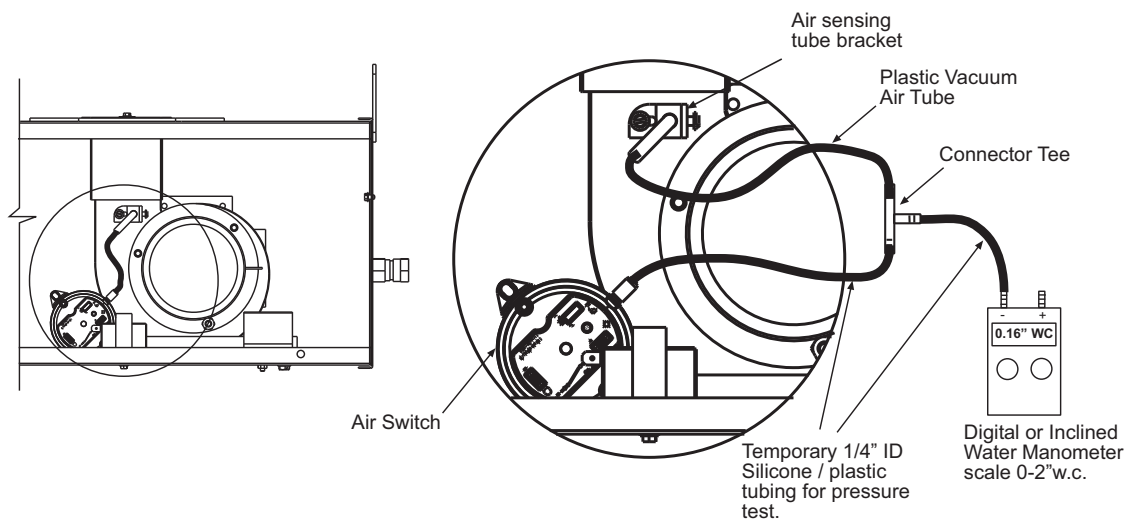

- a. Open access panel.
- b. Add tubing to connect the air switch with the connector tee and the existing tubing.
- c. Connect plastic tubing of a digital or inclined water manometer with a 0-2" scale onto the connector tees.
- d. Turn heater on and wait until blower motor is activated.
- e. Observe air pressure from manometer. This should be higher than the set point 0.16" w.c. for correct operation.

**All pressures are with the heater in operation for at least 15 minutes.**

## 21.4) IGNITION SYSTEM CHECKS

### TO CHECK IGNITION CABLE.

- a. Make sure that the ignition cable does not touch any metal surface.
- b. Make sure that connections to the stud terminal and the igniter/sensor are clean and tight.
- c. Make sure that the ignition cable provides good electrical continuity.

### TO CHECK IGNITION SYSTEM GROUNDING.

(Nuisance shutdowns are often caused by a poor or erratic ground.) A common ground is required for the module, igniter, flame sensor and main burner.

- a. Check for good metal-to-metal contact between the igniter bracket and the main burner.
- b. Check the ground lead from the GND (BURNER) terminal on the module to the igniter bracket. Make sure connections are clean and tight. If the wire is damaged or deteriorated, replace it.
- c. Replace igniter/sensor with factory replacement part if insulator is cracked.

### TO CHECK SPARK IGNITION CIRCUIT.

**▲ WARNING:** The ignition circuit generates a 20,000 Volt open circuit and electrical shock can result.

- a. Check ignition cable.
- b. Check external fuse on the module.
- c. Verify power (24V) at module input terminals and output terminal to gas valve.
- d. Replace spark module if fuse and power are OK.

### TO CHECK FLAME SENSOR CIRCUIT.

- a. Turn off heater at thermostat.
- b. Connect a meter (dc microammeter scale) in series with the ground lead as shown in the diagram. Connect the meter as follows:
  - Disconnect the ground lead at the electronic control.
  - Connect the black (negative) meter lead to the electronic control GND terminal.
  - Connect the red (positive) meter lead to the free end of the ground lead.
- c. Restart the system and read the meter. The flame sensor current must be steady and measure at least 1.5 microamps.
- d. If the meter reads less than the minimum or if reading is unsteady:
  - Make sure burner flame is capable of providing a good rectification signal.
  - Make sure fasteners securing igniter/sensor are tightened to assure correct positions. **DO NOT** relocate igniter/sensor.
  - Check for excessive (over 1000°F) temperature at ceramic insulator on flame sensor. Excessive temperature can cause short to ground. **DO NOT** relocate igniter/sensor.
  - Check for cracked ceramic insulator, which can cause short to ground, and replace sensor if necessary.
  - Make sure that electrical connections are clean and tight. Replace damaged wire.
- e. If the meter reads below "0" on the scale, meter leads are reversed. Disconnect power and reconnect meter leads for proper polarity.
- f. Remove microammeter. Return system to normal operation.

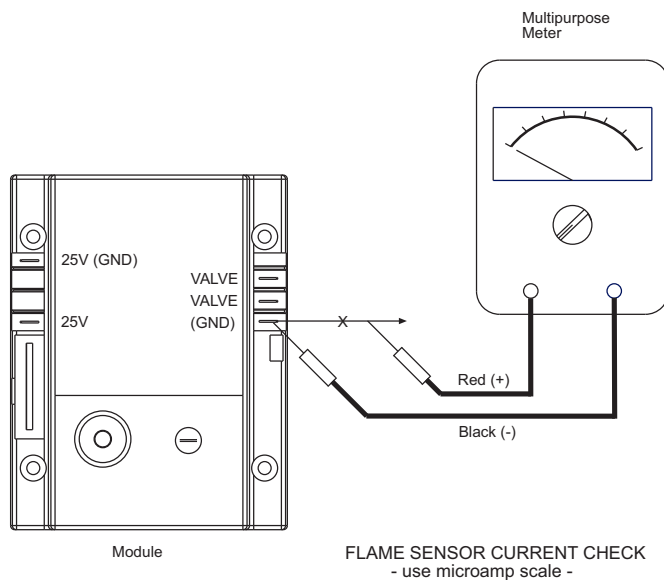

## 21.5) MOTOR AND BLOWER WHEEL CHECK

If draft inducer motor fails to run:

- a. Check power supply to junction box.
- b. Check for loose or broken motor lead wire.
- c. Check to see that blower wheel turns freely and is not rubbing housing. Blower wheel may have worked loose from shaft and jammed against housing.
- d. Check for blower wheel damage; replace if necessary. If no damage, readjust blower wheel on shaft & retighten set screw.
- e. If all above does not correct, replace motor.

## 22.0) INSTALLATION DATA

Date of Installation: \_\_\_\_\_ # of Heaters in System: \_\_\_\_\_

Serial No. \_\_\_\_\_

Model: **RSTP** \_\_\_\_\_ N = Natural Gas  
L = Propane Gas

## 23.0) REPLACEMENT PARTS GUIDE

CONTROL COMPONENTS		
Item No.	Part No.	Description
1	30314120	Ignition Cable Assembly
2	30216000	Spark Electrode - #PSE-GF2
3	03763000	Flame Sensor - #PSE-GF3
4	42387000	Entrance Cone & Support Assembly
5	04702000	Clamp, Manifold
6	42393000	Clamp, Burner
7	30175000	Brass Nipple - 1/2
8	41971000	Burner Assembly
9	03339020	Plug - 1/8
10	03259010	Main Burner Orifice (#1) Nat. (RSTP15C-N5D)
11	03259950	Main Burner Orifice ("D") Nat. (RSTP17C-N5D)
12	03259260	Main Burner Orifice (#26) LP (RSTP17C-L5D)
13	03333140	Nipple - 1/2 x 4"
14	30333030	Gas Valve - VR8205A-2008 @ 3-1/2"WC Nat.
15	30333040	Gas Valve - VR8205A-2081 @ 10"WC LP
16	03602100	Compression Union - 5/8 Tube x 1/2 NPT
17	03600040	Compression Sleeve - 5/8 Tube
18	03601040	Compression Nut - 5/8 Tube
19	42372000	Manifold Tubing
20	30244000	Compression Fitting - 5/8 Tube x 1/2 NPT
21	43143000	Draft Inducer Assembly (w/Air Switch)
22	43142000	Draft Inducer Housing Assembly
23	03723000	Blower Wheel
24	43221000	Motor Gasket
25	30347000	Motor Spacer - 5/16"OD x 1"
26	42740000	Motor Plate
27	03721000	Motor - 115V 1/20HP 1.73A 60Hz
28	03988070	Tubing, Silicone - 7"
29	30186201	Air Switch #NS2-0307-00 set @ -.11"WC ORANGE
30	42744020	Air Sensing Tube
31	42742000	Air Sensing Tube Clamp
32	42377000	Flue Collar - Outlet
33	42851000	Vent Collar Assembly
34	42392000	Clamp - Flue Collar
35	42395000	Gasket - Flue Collar
36	42391000	Extrusion Bracket
37	42365000	Control Mounting Panel
38	42368000	Extension Panel - RH
39	42369000	Extension Panel - LH
40	42374000	Cover Panel - Perforated
41	42389000	Cover Panel - Solid
42	42448000	Access Panel Assembly
43	42929000	Suspension Bracket - "L" Shaped
44	40481000	Suspension Bracket - 3"
45	42376000	Flue Collar - Inlet (5/8" dia. holes)
46	30356040	Spark Module - #S87K-1032
47	42398020	Monitoring Light - Green
48	42398070	Monitoring Light - Red
49	42398030	Monitoring Light - Amber
50	42709000	Terminal Block Shield

CONTROL COMPONENTS		
Item No.	Part No.	Description
51	30279000	Transformer - 120/24V 20VA 50/60Hz
52	30281000	Terminal Block - #EK-204

Labels / Manual			
Item No.	Part No.	Description	Qty.
53	43206000	Installation and Operation Instructions (not shown)	1
54	42360000	Label, Connection Wire Diagram	1
55	42785000	Label, Ladder Wire Diagram	1
56	42309000	Label, Clearance to Combustibles	1
57	42309010	Label, Gas Connector Warning	1
58	42848000	Label, Nameplate	1
59	42013000	Label, "Space-Ray" Logo	1
60	42922040	Label, Side Wall Venting	1
61	42834000	Label, 120V Caution	1
62	42875000	Label, Warning	1

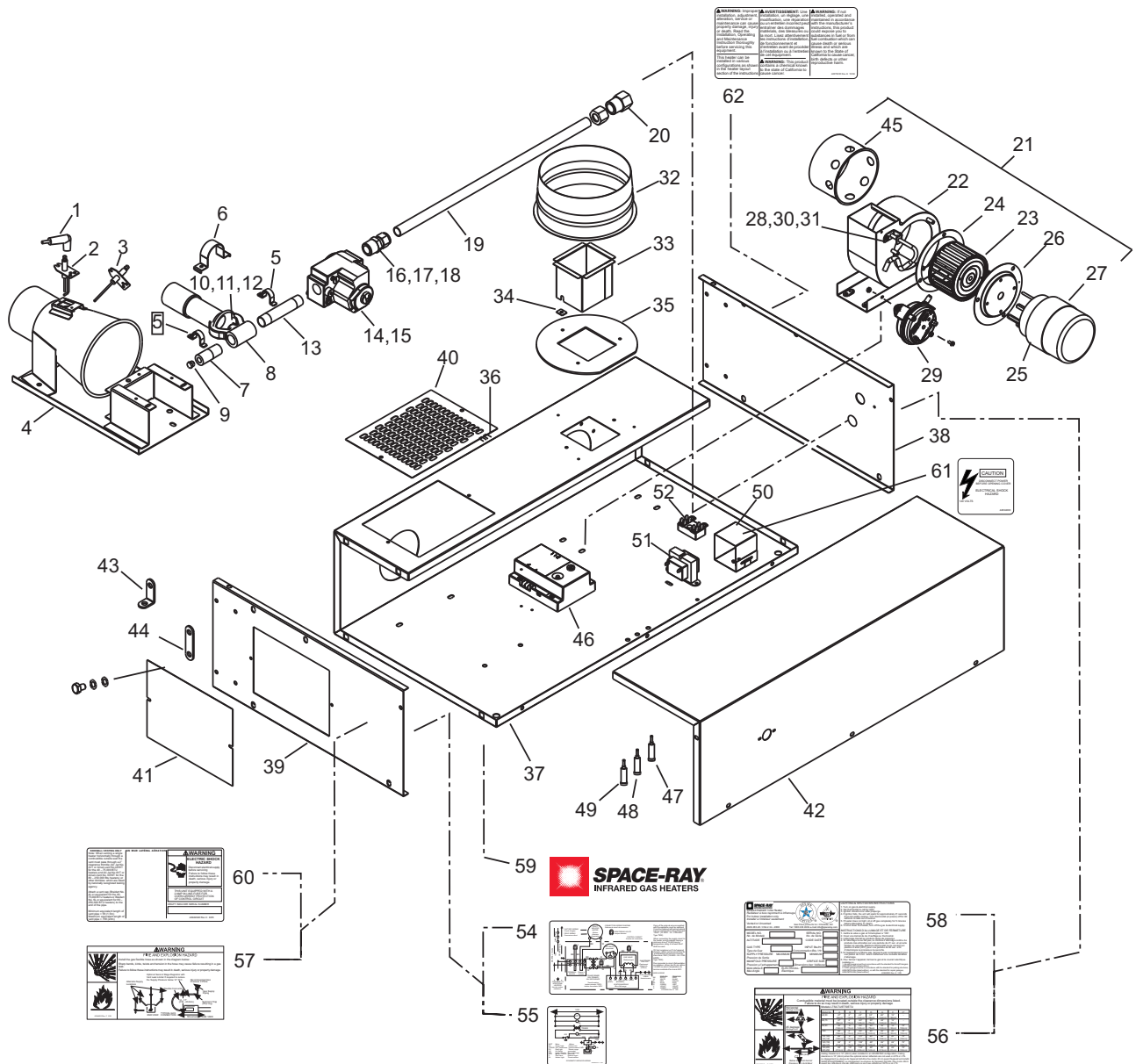

BODY COMPONENTS		
Item No.	Part No.	Description
55	40481010	Suspension Bracket - 4"
56	40531000	Reflector - Short
57	40531010	Reflector - Long
58	40788000	Side Rail
59	40919010	Extrusion - Reflector
60	42367000	Foot End Panel
61	43159000	Tube Assembly
62	42378010	Tube Channel Retainer
63	42386000	Suspension Panel Assembly
64	42396010	Brace - Cross
65	42396020	Brace - Diagonal
66	42873000	"U" Bolt Clamp

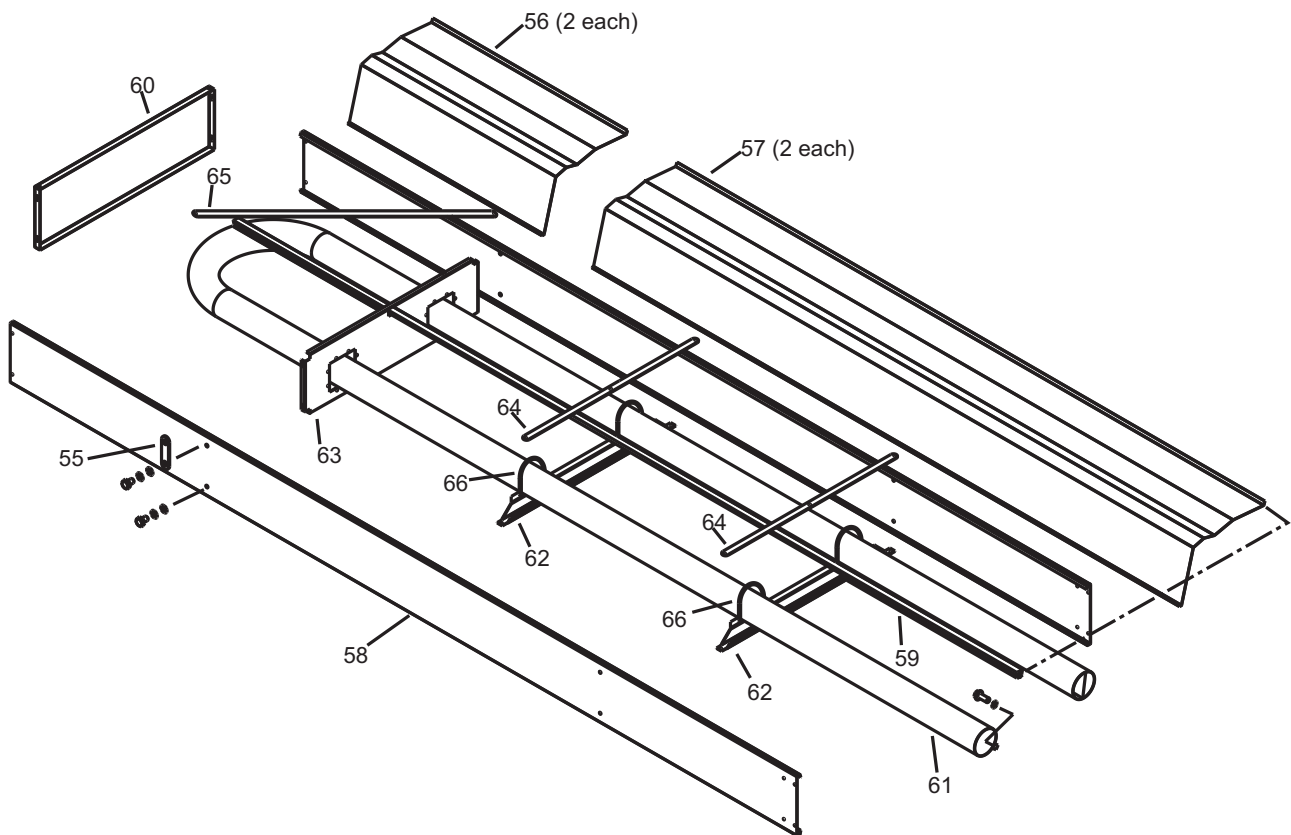

Most parts are assembled together at the factory using pop rivets. When replacing parts, these rivets may be substituted with standard screws, washers, and nuts, which can be purchased at any local hardware store.

**ALL ILLUSTRATIONS ARE INTENDED TO GIVE THE GENERAL IMPRESSION OF UNITS ONLY. WE RESERVE THE RIGHT TO ALTER ANY SPECIFICATION WITHOUT NOTICE.**